



# MURATORI

**TIPO-TYPE-TYP  
MT 40 F**

**CATALOGO RICAMBI**  
**Catalogue Pièces Detachées**  
**Ersatzteilkatalog**  
**Spare Parts Catalogue**  
**Catálogo Recambios**

**EDIZIONE 09/2019**



Per ordinare parti di ricambio specificare:

- tipo e matricola della macchina (apposti sulla macchina o sui documenti di acquisto);
- numero del riferimento del pezzo nel disegno (Pos.), numero della tavola (Tav.) e numero di codice

**N.B.:** le indicazioni destro o sinistro vengono date guardando la macchina da dietro.

*Pour les commandes de pièces de rechange veuillez spécifier:*

- *type et numéro de série de la machine (indiqués sur la machine et sur le bon d'achat);*
- *numéro de référence du pièce sur le plan (Pos.), numéro du plan (Tav.) et numéro de code (codice)*

**N.B.:** *les indications droite ou gauche sont données en regardant la machine par derrière.*

Zum Bestellen von Ersatzteilen folgendes angeben:

- Typ und Serien-Nr. der Maschine (zu finden auf der Maschine oder der Einkaufspapieren);
- Bezug-Nr. des Ersatzteils auf der Zeichnung (Pos.), Zeichnungsnummer (Tav.) und Kodenummer (codice)

**N.B.:** die Angaben rechts und links verstehen sich so, dass man hinter der Maschine steht.

*When ordering spare parts specify:*

- *machine type and serial number (found on the machine or on the purchasing documents);*
- *reference number of the part on the relative drawing (Pos.) number of the drawing (Tav.) and part number (codice)*

**N.B.:** *right-hand or left-hand indications are made by viewing the machine from the rear.*

**TAV. 1.0**

GRUPPO TELAIO  
ENSEMBLE CHASSIS  
SATZ FÜR RAHMEN  
KIT FOR FRAME

**TAV. 2.0**

GRUPPO RULLO ROTORE  
ENSEMBLE ROTOR  
SATZ FÜR ROTOR  
KIT FOR ROTOR

**TAV. 3.0**

GRUPPO MOLTIPLICATORE  
ENSEMBLE MULTIPLICATEUR  
SATZ FÜR GETRIEBE  
KIT FOR GEAR BOX

**TAV. 4.0**

GRUPPO RULLO POSTERIORE  
ENSEMBLE ROULEAU ARRIERE  
SATZ HINTERE WALZE  
KIT REAR ROLLER

**TAV. 5.0**

ACCESSORI A COMPLETAMENTO  
OPTIONS D'ACHEVEMENT  
ZUBEHÖRE ZUR ERGÄNZUNG DER MASCHINE  
CHOICE OF EQUIPMENT COMPLETING MACHINE

**TAV. 6.0**

ALBERO CARDANICO COMPLETO - AB409SF  
ARBRE A JOINTS DE CARDAN - AB409SF  
KARDANWELLE - AB409SF  
PTO SHAFT - AB409SF

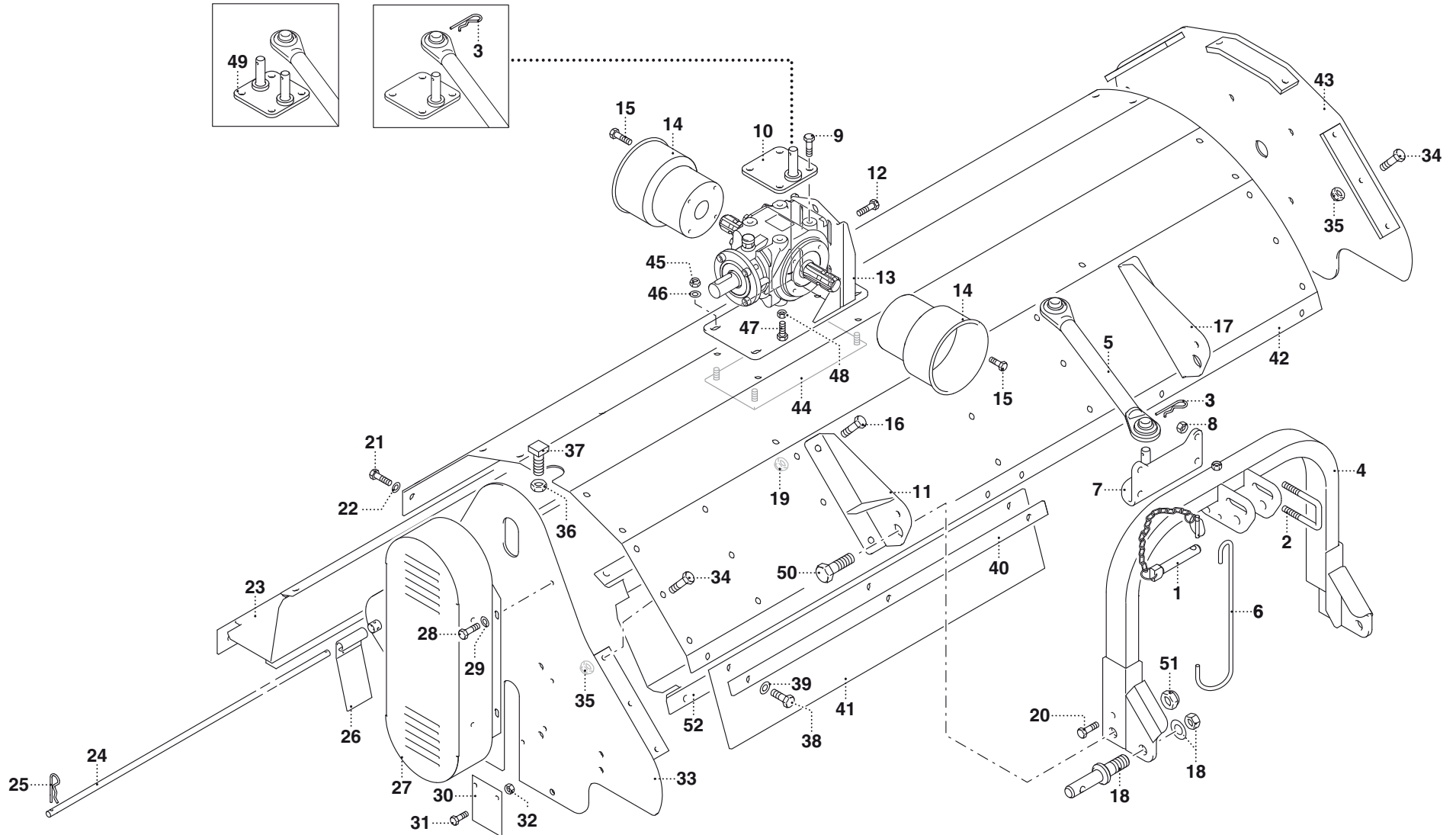

# MURATORI MT 40 F

TAV. 1.0

POS.	N° CODICE	Q.	DESCRIZIONE	DESIGNATION	BENENNUNG	DESCRIPTION	DESIGNAZIONE	Da matr. De nr. serie Vom Seriennr. From serial nr.	Fino matr. Jusqu'au nr. serie Bis Seriennr. Up to serial nr.
1	68062000	1	PERNO	PIVOT	BOLZEN	PIN			
2	38028700	2	CAVALLOTTO	ARRETOIR	KLEMMSTÜCK	UBOLT			
3	64000300	2	COPIGLIA	COUPILLE	SPLINT	COTTER PIN	AR Ø 4		
4	40315700	1	ATTACCO	ATTACHE	ANSCHLUSS	ATTACHMENT			
5	40320000	1	TIRANTE	TIRANT	STANGE	TIEROD			
6	38024500	1	GANCIO	CROCHET	HAKEN	HOOK			
7	40319800	1	MENSOLA	CONSOLE	KONSOLE	BRACKET			
8	62010400	4	DADO	ECROU	MUTTER	NUT	M 10 x 1,5 AUTOBLOCC.		
9	60023000	4	VITE	VIS	SCHRAUBE	SCREW	TE 12 x 30 UNI 5739		
10	40319900	1	MENSOLA	CONSOLE	KONSOLE	BRACKET			
11	40320500	1	MENSOLA DX	CONSOLE (D)	KONSOLE (RECHTS)	BRACKET (RH)			
12	60023000	4	VITE	VIS	SCHRAUBE	SCREW	TE 12 x 30 UNI 5739		
13	40319600	1	SUPPORTO	SUPPORT	HALTERUNG	SUPPORT			
14	68061501	2	PROTEZIONE	PROTECTION	SCHUTZ	GUARD			
15	60015100	8	VITE	VIS	SCHRAUBE	SCREW	TE 8 x 16 UNI 5739		
16	60023000	6	VITE	VIS	SCHRAUBE	SCREW	TE 12 x 30 UNI 5739		
17	40320400	1	MENSOLA SX	CONSOLE (G)	KONSOLE (LINKS)	BRACKET (LH)			
18	68062000	2	PERNO COMPLETO	PIVOT COMPLET	KOMPL. BOLZEN	COMPLETE PIN			
19	62010600	8	DADO	ECROU	MUTTER	NUT	M 12 x 1,75 AUTOBLOCC.		
20	60021200	2	VITE	VIS	SCHRAUBE	SCREW	TE 12 x 35 UNI 5739		
21	60020400	6	VITE	VIS	SCHRAUBE	SCREW	TE 12 x 25 UNI 5739		
22	62010600	3	DADO	ECROU	MUTTER	NUT	M 12 x 1,75 AUTOBLOCC.		
23	40317800	1	CONTROTELAIO	FERMETURE	VERSCHLUSS	LOCK	105		
23	40317900	1	CONTROTELAIO	FERMETURE	VERSCHLUSS	LOCK	120		
23	40318000	1	CONTROTELAIO	FERMETURE	VERSCHLUSS	LOCK	140		
23	40318100	1	CONTROTELAIO	FERMETURE	VERSCHLUSS	LOCK	155		

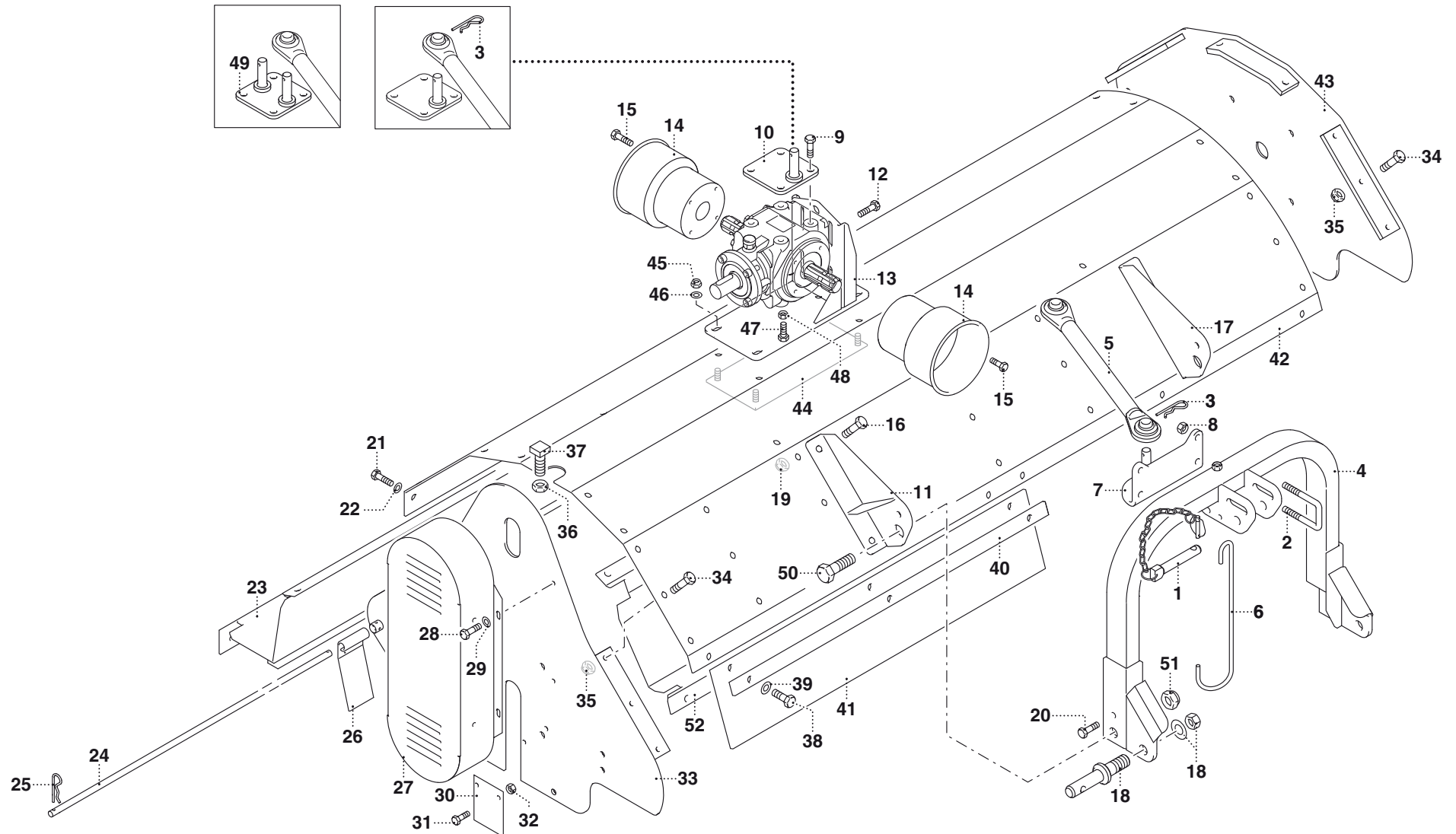

## MURATORI MT 40 F

TAV. 1.0

POS.	N° CODICE	Q.	DESCRIZIONE	DESIGNATION	BENENNUNG	DESCRIPTION	DESIGNAZIONE	Da matr. De nr. serie Vom Seriennr. From serial nr.	Fino matr. Jusqu'au nr. serie Bis Seriennr. Up to serial nr.
23	40318200	1	CONTROTELAIO	FERMETURE	VERSCHLUSS	LOCK	170		
23	40318300	1	CONTROTELAIO	FERMETURE	VERSCHLUSS	LOCK	185		
23	40318400	1	CONTROTELAIO	FERMETURE	VERSCHLUSS	LOCK	200		
24	38028000	1	SPINA	GOUPILLE	STIFT	PIN	105		
24	38028100	1	SPINA	GOUPILLE	STIFT	PIN	120		
24	38028200	1	SPINA	GOUPILLE	STIFT	PIN	140		
24	38028300	1	SPINA	GOUPILLE	STIFT	PIN	155		
24	38028400	1	SPINA	GOUPILLE	STIFT	PIN	170		
24	38028500	1	SPINA	GOUPILLE	STIFT	PIN	185		
24	38028600	1	SPINA	GOUPILLE	STIFT	PIN	200		
25	64000300	1	COPIGLIA	COUPILLE	SPLINT	COTTER PIN	AR Ø 3		
26	39128400		BANDELLA	BANDE	BAND	STRAP	L=70		
26	39164100		BANDELLA	BANDE	BAND	STRAP	L=25		
26	39164200		BANDELLA	BANDE	BAND	STRAP	L=35		
26	39164300		BANDELLA	BANDE	BAND	STRAP	L=45		
27	40219001	1	CARTER	CARTER	KETTENKASTEN	CASING			
28	60022800	4	VITE	VIS	SCHRAUBE	SCREW	TE 8 x 20 UNI 5739		
29	61006200	4	RONDELLA	RONDELLE	SCHEIBE	WASHER	PIANA Øi 9 Øe 24 SP 1,5		
30	39340700	1	CHIUSURA	FERMETURE	VERSCHLUSS	GRIPPING			
31	60022800	2	VITE	VIS	SCHRAUBE	SCREW	TE 8 x 20 UNI 5739		
32	62010200	2	DADO	ECROU	MUTTER	NUT	M 8 x 1,25 AUTOBLOCC.		
33	40319200	1	FIANCO SX	FLANC (G)	SEITENWAND (LINKS)	SIDE FRAME (LH)			131652
33	40324700	1	FIANCO SX	FLANC (G)	SEITENWAND (LINKS)	SIDE FRAME (LH)		131653	
34	60044400		VITE	VIS	SCHRAUBE	SCREW	TE 12 x 20 UNI 5739		
35	61011300		RONDELLA	RONDELLE	SCHEIBE	WASHER			
36	62014500	1	DADO	ECROU	MUTTER	NUT	M 20 x 2,5 UNI 5589		





# MURATORI MT 40 F

TAV. 1.0

POS.	N° CODICE	Q.	DESCRIZIONE	DESIGNATION	BENENNUNG	DESCRIPTION	DESIGNAZIONE	Da matr. De nr. serie Vom Seriennr. From serial nr.	Fino matr. Jusqu'au nr. serie Bis Seriennr. Up to serial nr.
37	60010800	1	VITE	VIS	SCHRAUBE	SCREW	TE 20 x 60 UNI 5739		
38	60021200		VITE	VIS	SCHRAUBE	SCREW	TE 12 x 35 UNI 5739		
39	62010600		DADO	ECROU	MUTTER	NUT	M 12 x 1,75 AUTOBLOCC.		
40	30213100	2	PIATTO	PLAQUE	PLATTE	DISC	105		
40	30213200	2	PIATTO	PLAQUE	PLATTE	DISC	120		
40	30213300	2	PIATTO	PLAQUE	PLATTE	DISC	140		
40	30213400	2	PIATTO	PLAQUE	PLATTE	DISC	155		
40	30213500	2	PIATTO	PLAQUE	PLATTE	DISC	170		
40	30213600	2	PIATTO	PLAQUE	PLATTE	DISC	185		
40	30213700	2	PIATTO	PLAQUE	PLATTE	DISC	200		
41	68121700	2	BANDELLA	BANDE	BAND	STRAP	105		
41	68121800	2	BANDELLA	BANDE	BAND	STRAP	120		
41	68121900	2	BANDELLA	BANDE	BAND	STRAP	140		
41	68122000	2	BANDELLA	BANDE	BAND	STRAP	155		
41	68122100	2	BANDELLA	BANDE	BAND	STRAP	170		
41	68122200	2	BANDELLA	BANDE	BAND	STRAP	185		
41	68122300	2	BANDELLA	BANDE	BAND	STRAP	200		
42	39335600	1	TELAIO	CHASSIS	RAHMEN	FRAME	105		
42	39335700	1	TELAIO	CHASSIS	RAHMEN	FRAME	120		
42	39335800	1	TELAIO	CHASSIS	RAHMEN	FRAME	140		
42	39335900	1	TELAIO	CHASSIS	RAHMEN	FRAME	155		
42	39336000	1	TELAIO	CHASSIS	RAHMEN	FRAME	170		
42	39336100	1	TELAIO	CHASSIS	RAHMEN	FRAME	185		
42	39336200	1	TELAIO	CHASSIS	RAHMEN	FRAME	200		
43	40319300	1	FIANCO DX	FLANC (D)	SEITENWAND (RECHTS)	SIDE FRAME (RH)			131652
43	40324800	1	FIANCO DX	FLANC (D)	SEITENWAND (RECHTS)	SIDE FRAME (RH)		131653	

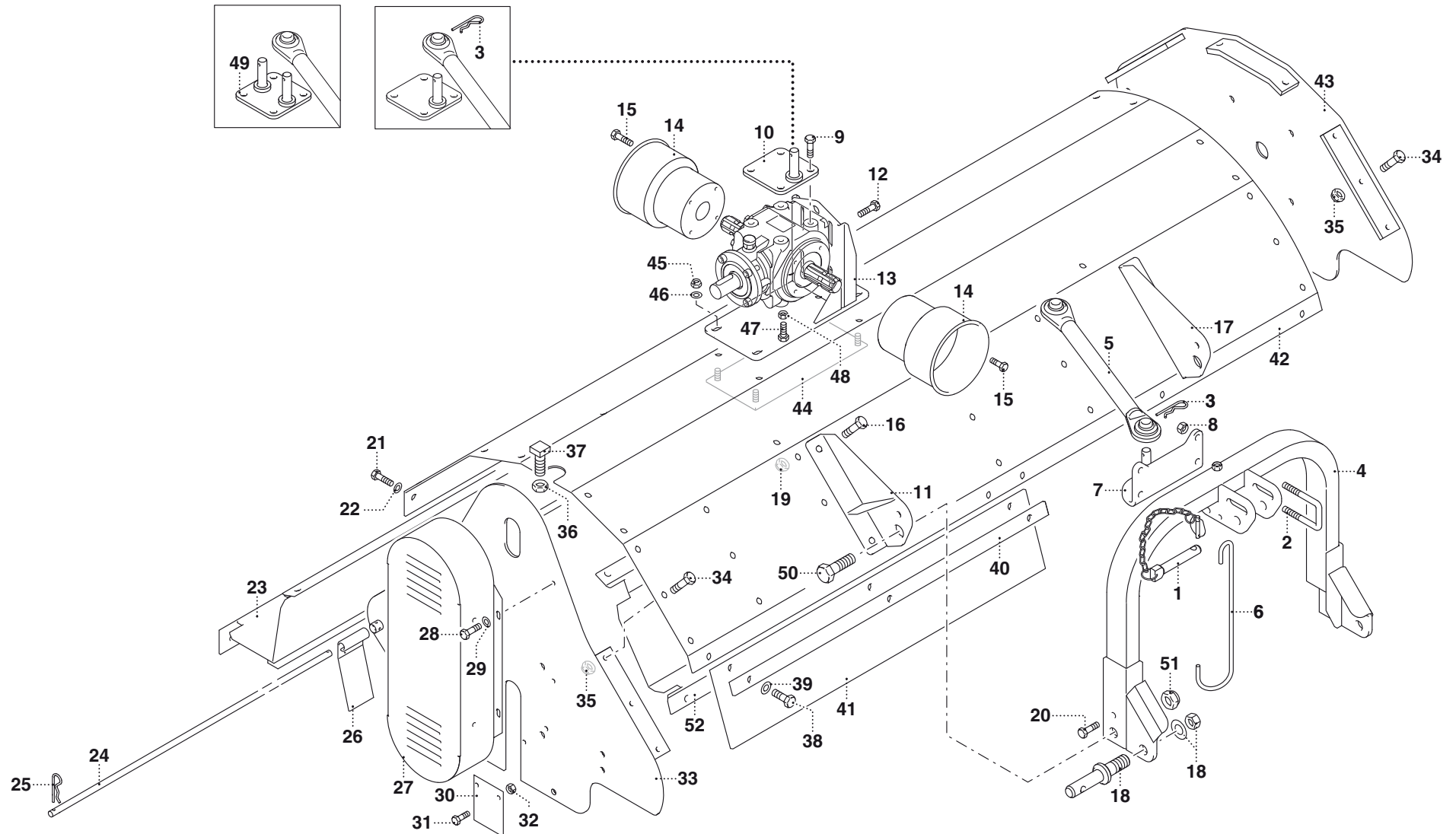



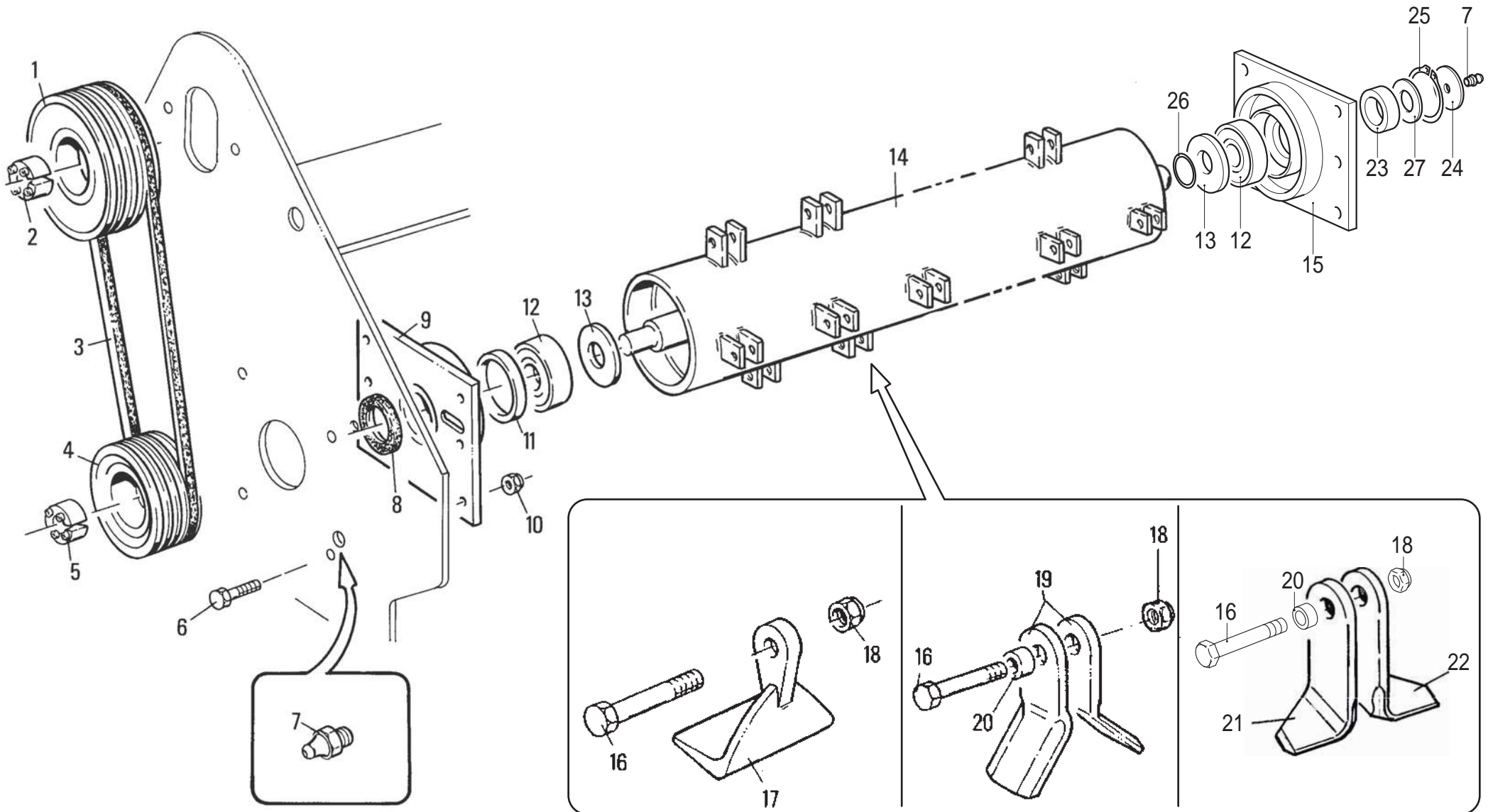

## MURATORI MT 40 F

TAV. 2.0

POS.	N° CODICE	Q.	DESCRIZIONE	DESIGNATION	BENENNUNG	DESCRIPTION	DESIGNAZIONE	Da matr. De nr. serie Vom Seriennr. From serial nr.	Fino matr. Jusqu'au nr. serie Bis Seriennr. Up to serial nr.
1	68059300	1	PULEGGIA	POULIE	RIEMENSCHLEIBE	PULLEY	Ø 160 2 SPB (105)		
1	68059600	1	PULEGGIA	POULIE	RIEMENSCHLEIBE	PULLEY	Ø 160 3 SPB (120-140)		
1	68113900	1	PULEGGIA	POULIE	RIEMENSCHLEIBE	PULLEY	Ø 160 4 SPB (155-200)		
2	68084100	1	CALETTATORE	DOUILLE DE SERRAGE	SPANNBÜCHSE	LOCKING DEVICE	Øe 65 Øi 35		
3	68084900		CINGHIA	COURROIE	KEILRIEMEN	BELT	B 46		
4	68079200	1	PULEGGIA	POULIE	RIEMENSCHLEIBE	PULLEY	Ø 120 2 SPB (105)		
4	68079300	1	PULEGGIA	POULIE	RIEMENSCHLEIBE	PULLEY	Ø 120 3 SPB (120-140)		
4	68082400	1	PULEGGIA	POULIE	RIEMENSCHLEIBE	PULLEY	Ø 120 4 SPB (155-200)		
5	68059500	1	CALETTATORE	DOUILLE DE SERRAGE	SPANNBUCHSE	LOCKING DEVICE	Øe 65 Øi 40		
6	60026700	8	VITE	VIS	SCHRAUBE	SCREW	TE 14x30 UNI 5739		
7	64001800	2	INGRASSATORE	GRAISSEUR	SCHMIERNIPPEL	GREASE FITTING	M10 x 1		
8	66014100	1	ANELLO TENUTA	JOINT D'ETANCHEITE	DICHTUNGSRING	JUNT RING	45 x 55 x 6 "G"		
9	40218600	1	SUPPORTO SX	SUPPORT (G)	HALTER (LINKS)	SUPPORT (LH)			131652
9	40324600	1	SUPPORTO SX	SUPPORT (G)	HALTER (LINKS)	SUPPORT (LH)		131653	
10	62010800	8	DADO	ECROU	MUTTER	NUT	M 14 x 2 AUTOBLOCC.		
11	68011000	1	SPESSORE	EPAISSEUR	BEILAGERING	SPACER	55 x 45 x 1		
12	67018200	2	CUSCINETTO	ROULEMENT	LAGER	BEARING	2209		
13	39237400	2	PROTEZIONE	PROTECTION	SCHUTZ	GUARD			
14	42064300	1	ROTORE	ROTOR	ROTOR	ROTOR	105		
14	42064400	1	ROTORE	ROTOR	ROTOR	ROTOR	120		
14	42064500	1	ROTORE	ROTOR	ROTOR	ROTOR	140		
14	42064600	1	ROTORE	ROTOR	ROTOR	ROTOR	155		
14	42064700	1	ROTORE	ROTOR	ROTOR	ROTOR	170		
14	42064800	1	ROTORE	ROTOR	ROTOR	ROTOR	185		
14	42084100	1	ROTORE	ROTOR	ROTOR	ROTOR	200		
15	40218500	1	SUPPORTO DX	SUPPORT (D)	HALTER (RECHTS)	SUPPORT (RH)			131652

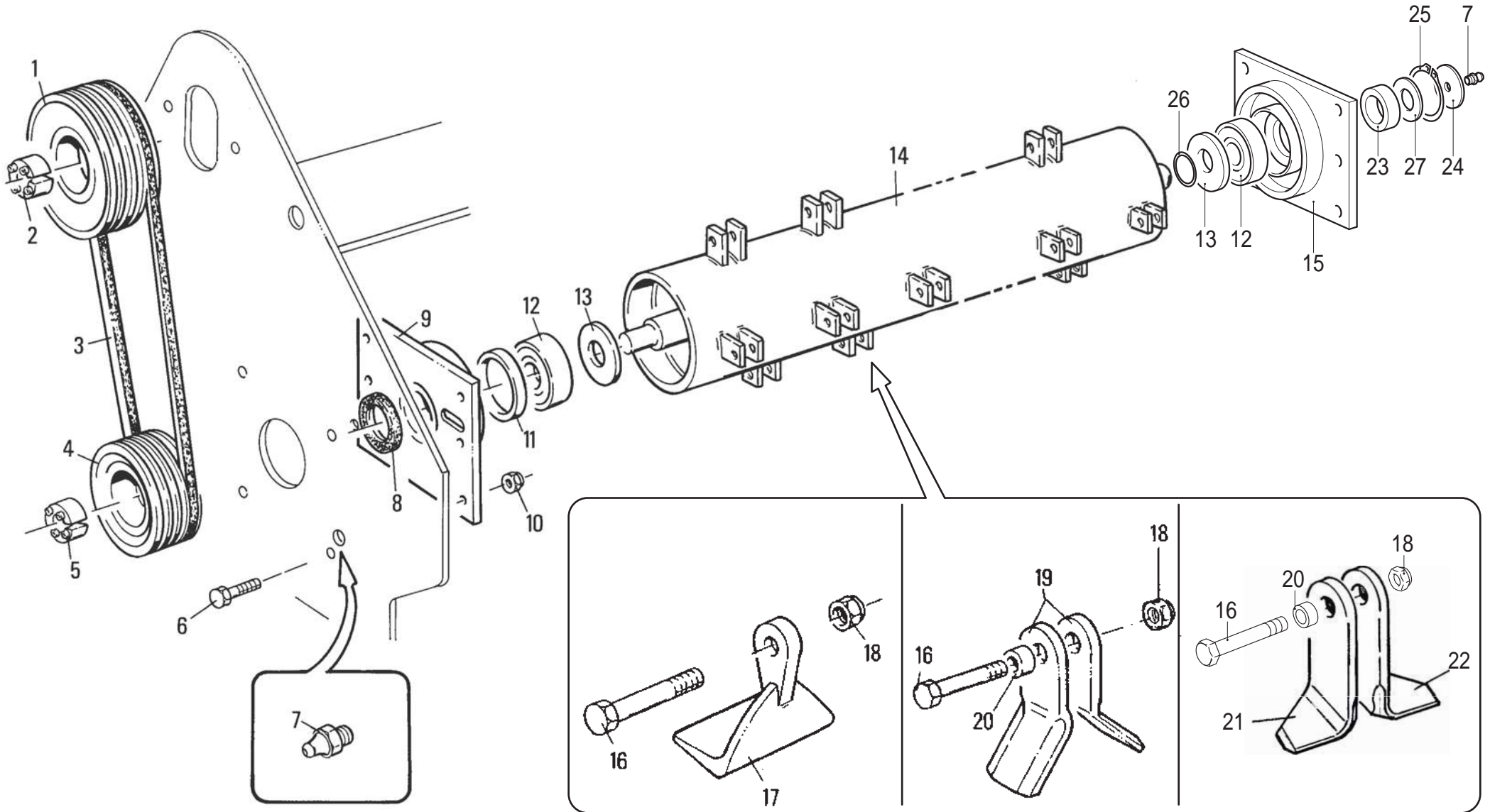



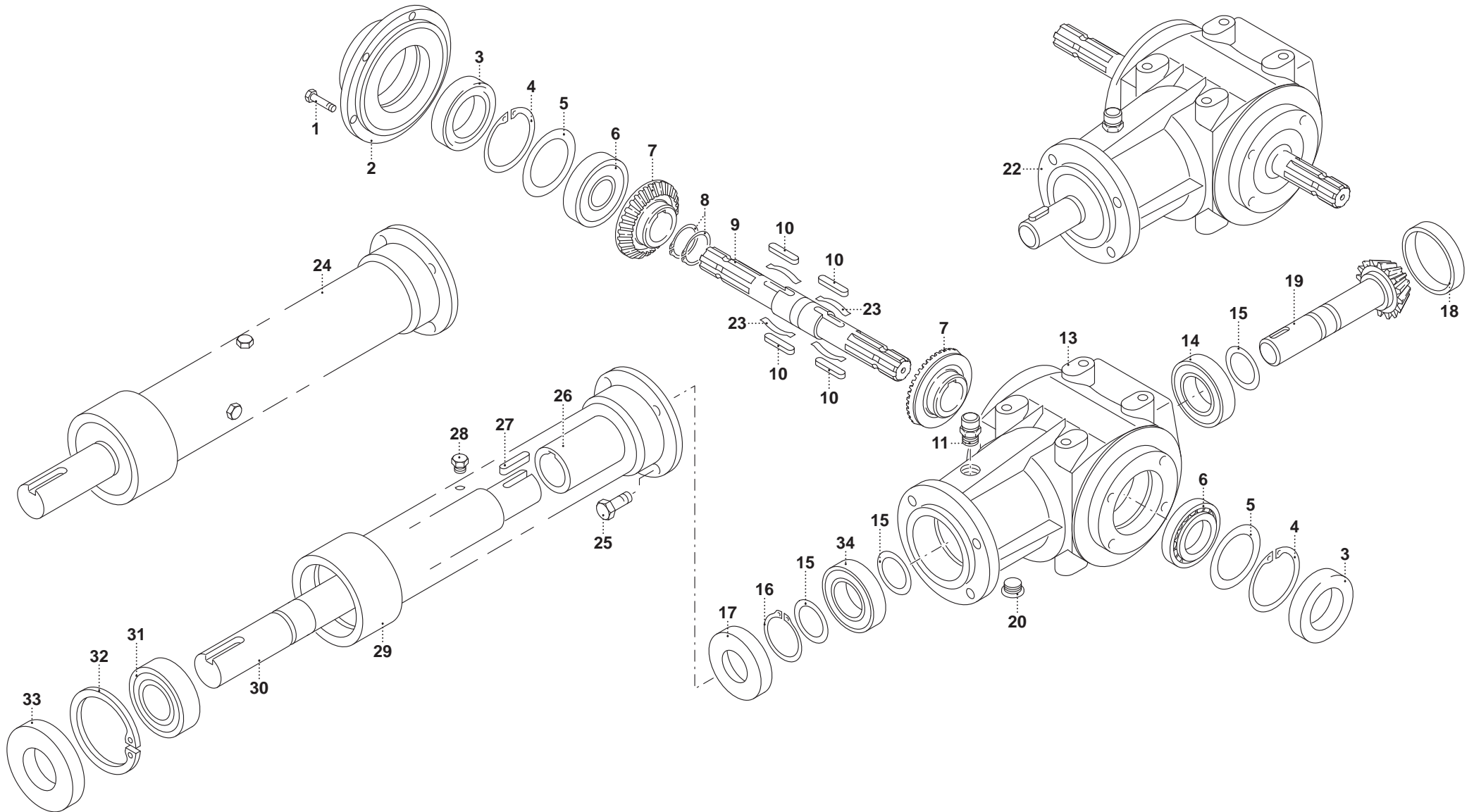

UN09-R-0222-BM



# MURATORI MT 40 F

TAV. 3.0

POS.	N° CODICE	Q.	DESCRIZIONE	DESIGNATION	BENENNUNG	DESCRIPTION	DESIGNAZIONE	Da matr. De nr. serie Vom Seriennr. From serial nr.	Fino matr. Jusqu'au nr. serie Bis Seriennr. Up to serial nr.
1	60021600	8	VITE	VIS	SCHRAUBE	SCREW	TE 10x20 UNI 5739		
2	01020000	1	COPERCHIO	COUVERCLE	DECKEL	COVER			
3	66001400	2	ANELLO TENUTA	JOINT D'ETANCHEITE	DICHTUNGSRING	JUNT RING	35x80x10		
4	63000200	2	ANELLO ELASTICO	ARRETOIR	SPANNRING	SNAP-RING	Øi 80 UNI 7437		
5	68075500		SPESSORE	EPAISSEUR	DISTANZRING	SPACER	80x70		
6	67002100	2	CUSCINETTO	ROULEMENT	LAGER	BEARING	6307		
7	10051100	2	CORONA	COURONNE	KRANZ	CROWN			
8	63005000	2	ANELLO ELASTICO	ARRETOIR	SPANNRING	SNAP-RING	Øe 42 UNI 7435		
9	31099900	1	ALBERO	ARBRE	WELLE	SHAFT			
10	65003600	4	LINGUETTA	CLAVETTE	FEDER	KEY			
11	68085600	1	TAPPO	BOUCHON	STOPFEN	PLUG	3/8		
12	68111900	1	GOMITO	COUDE	WINKELSTÜCK	BBEND			
13	01020500	1	SCATOLA	CARTER	GEHÄUSE	GEARBOX			
14	67000300	1	CUSCINETTO	ROULEMENT	LAGER	BEARING	30207		
15	68052300		SPESSORE	EPAISSEUR	DISTANZRING	SPACER	48x35		
16	63006900	1	ANELLO ELASTICO	ARRETOIR	SPANNRING	SNAP-RING	Øe 35 UNI 7436		
17	66014800	1	ANELLO TENUTA	JOINT D'ETANCHEITE	DICHTUNGSRING	JUNT RING	35x72x10		
18	68067300	1	CAPPELOTTO	BOUCHON	ABSCHLUSSKAPPE	CAP NUT			
19	10050100	1	ALBERO	ARBRE	WELLE	SHAFT			
20	68008700	1	TAPPO	BOUCHON	STOPFEN	PLUG	3/8		
21	68085600	1	TAPPO	BOUCHON	STOPFEN	PLUG			
22	46042300	1	MOLTIPLICATORE	MULTIPLICATEUR	GETRIEBE	GEAR BOX			
23	68127200	4	MOLLA	RESSORT	FEDER	SPRING			
24	45177200	2	PROLUNGA COMPLETA	RALLONGE COMPLETE	KOMPLETTVERLÄNGERUNGSROHR	COMPLETE EXTENSION	105-140		
24	45177300	2	PROLUNGA COMPLETA	RALLONGE COMPLETE	KOMPLETTVERLÄNGERUNGSROHR	COMPLETE EXTENSION	155-185		
24	45177400	2	PROLUNGA COMPLETA	RALLONGE COMPLETE	KOMPLETTVERLÄNGERUNGSROHR	COMPLETE EXTENSION	200		

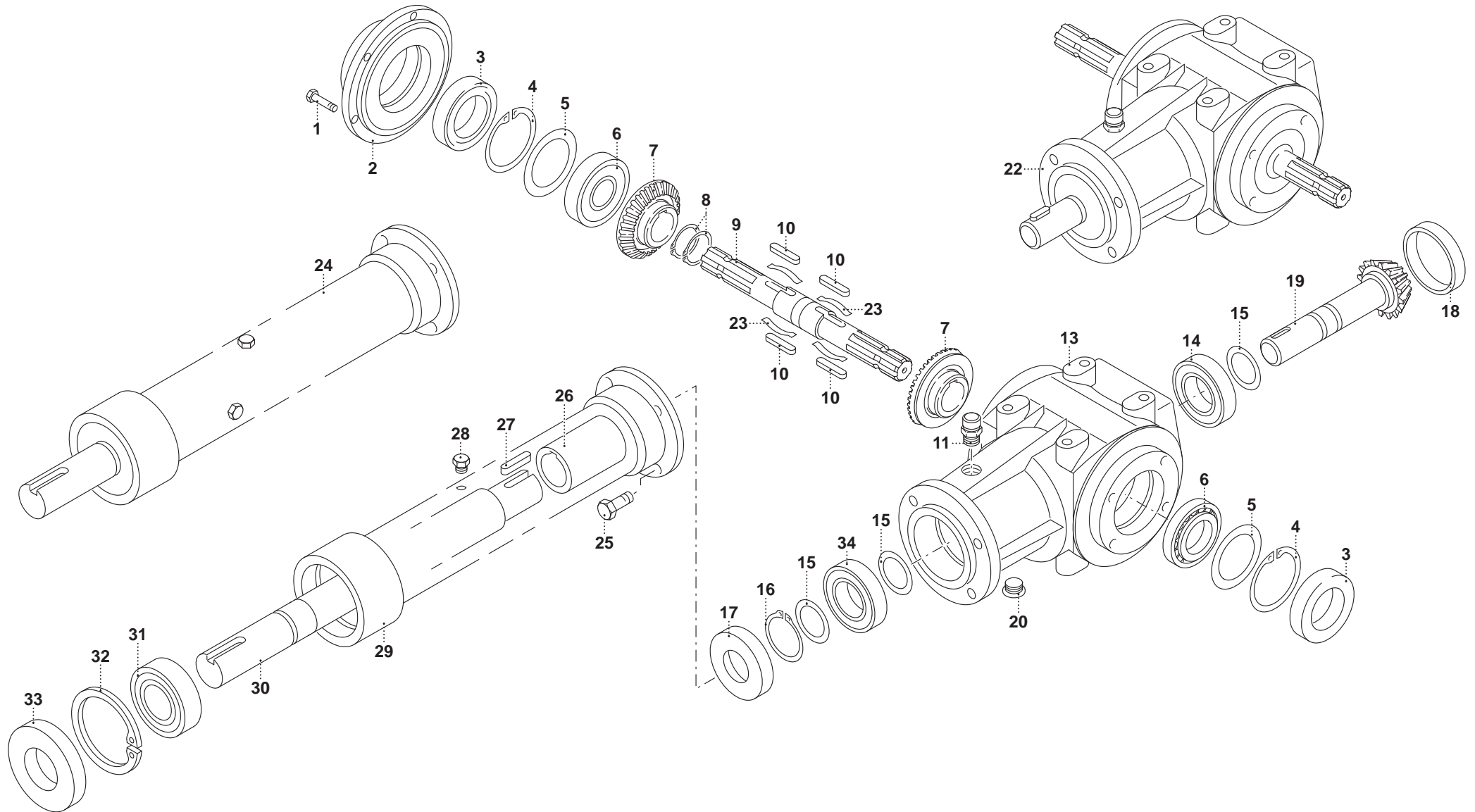



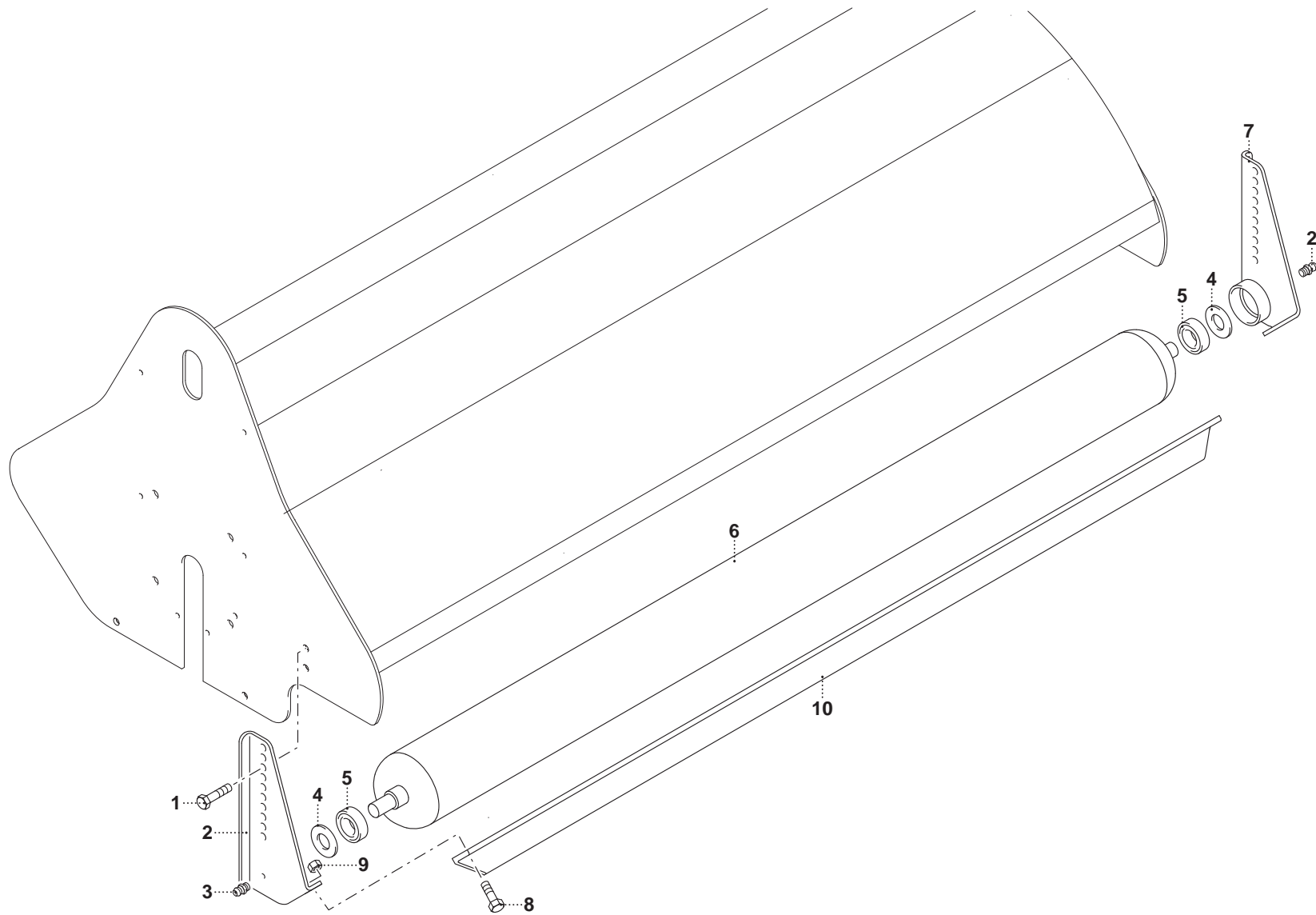

# MURATORI MT 40 F

TAV. 4.0

POS.	N° CODICE	Q.	DESCRIZIONE	DESIGNATION	BENENNUNG	DESCRIPTION	DESIGNAZIONE	Da matr. De nr. serie Vom Seriennr. From serial nr.	Fino matr. Jusqu'au nr. serie Bis Seriennr. Up to serial nr.
1	60021200	4	VITE	VIS	SCHRAUBE	SCREW	TE 12 x 35 UNI 5739		
2	64001800	2	INGRASSATORE	GRAISSEUR	SCHMIERNIPPEL	GREASE FITTING	M 10 x 1		
3	40321400	1	SUPPORTO SX	SUPPORT (G)	TRÄGER (L)	SUPPORT (LH)			
4	39200500	2	PROTEZIONE	PROTECTION	SCHUTZ	GUARD			
5	67018100	2	CUSCINETTO	ROULEMENT	LAGER	BEARING	6305		
6	42065000	1	RULLO LIVELLATORE	ROULEAU NIV.	STÜTZWALZE	LEVELLING ROLLER	105		
6	42065100	1	RULLO LIVELLATORE	ROULEAU NIV.	STÜTZWALZE	LEVELLING ROLLER	120		
6	42065200	1	RULLO LIVELLATORE	ROULEAU NIV.	STÜTZWALZE	LEVELLING ROLLER	140		
6	42065300	1	RULLO LIVELLATORE	ROULEAU NIV.	STÜTZWALZE	LEVELLING ROLLER	155		
6	42065400	1	RULLO LIVELLATORE	ROULEAU NIV.	STÜTZWALZE	LEVELLING ROLLER	170		
6	42065500	1	RULLO LIVELLATORE	ROULEAU NIV.	STÜTZWALZE	LEVELLING ROLLER	185		
6	42084200	1	RULLO LIVELLATORE	ROULEAU NIV.	STÜTZWALZE	LEVELLING ROLLER	200		
7	40321500	1	SUPPORTO DX	SUPPORT (D)	TRÄGER (R)	SUPPORT (RH)			
8	60023000	2	VITE	VIS	SCHRAUBE	SCREW	TE 10 x 35		
9	62010400	2	DADO	ECROU	MUTTER	NUT	M 10 x 1,5 AUTOBLOCC.		
10	34031500	1	RASCHIARULLO	GRATTOIR	ABSTREIFER	SCRAPER	105		
10	34031600	1	RASCHIARULLO	GRATTOIR	ABSTREIFER	SCRAPER	120		
10	34032500	1	RASCHIARULLO	GRATTOIR	ABSTREIFER	SCRAPER	140		
10	34031700	1	RASCHIARULLO	GRATTOIR	ABSTREIFER	SCRAPER	155		
10	34031800	1	RASCHIARULLO	GRATTOIR	ABSTREIFER	SCRAPER	170		
10	34031900	1	RASCHIARULLO	GRATTOIR	ABSTREIFER	SCRAPER	185		
10	34032600	1	RASCHIARULLO	GRATTOIR	ABSTREIFER	SCRAPER	200		

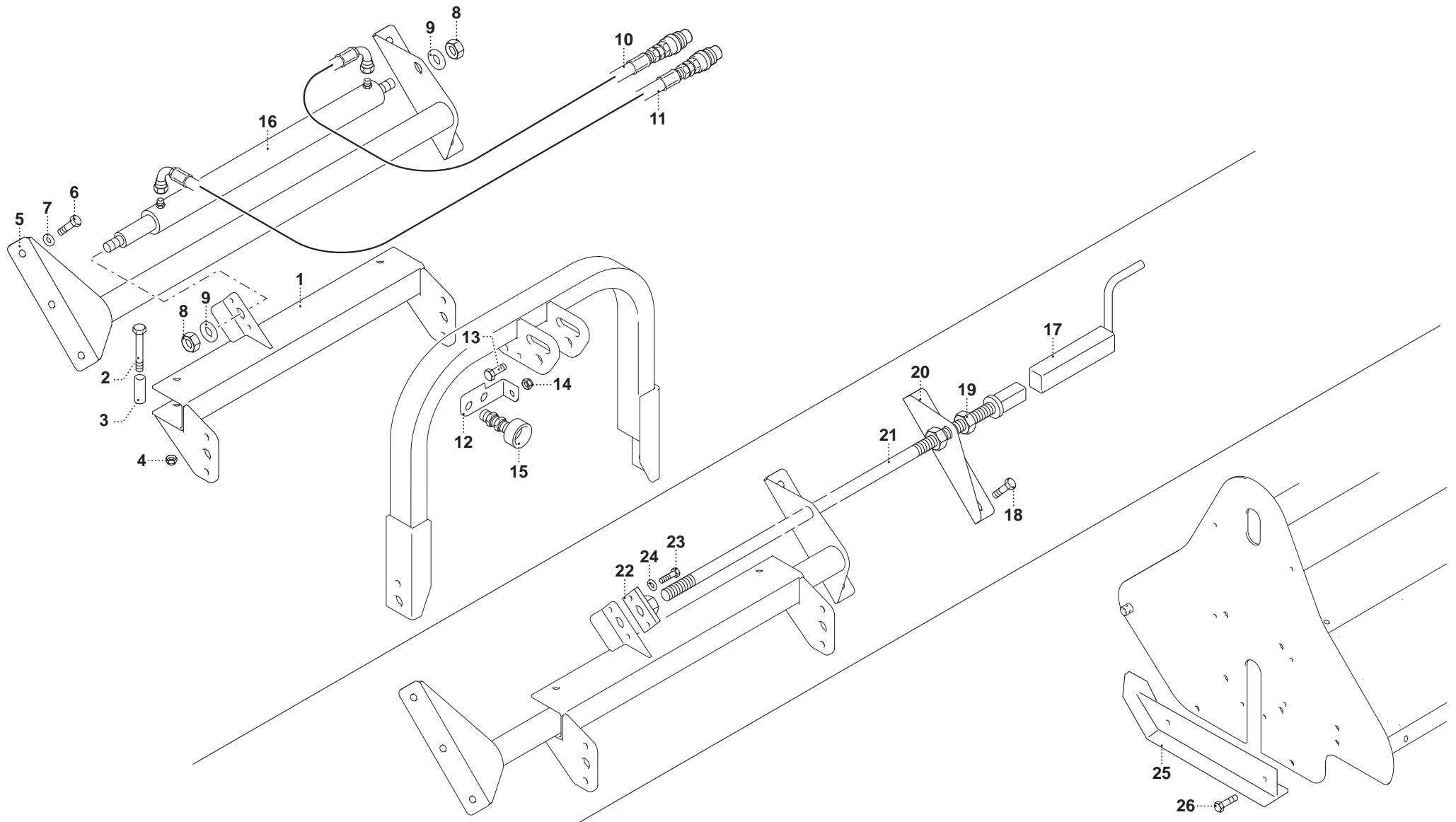

# MURATORI MT 40 F

**TAV. 5.0**

POS.	N° CODICE	Q.	DESCRIZIONE	DESIGNATION	BENENNUNG	DESCRIPTION	DESIGNAZIONE	Da matr. De nr. serie Vom Seriennr. From serial nr.	Fino matr. Jusqu'au nr. serie Bis Seriennr. Up to serial nr.
1	40267900	1	CARRELLO	CHARIOT	WAGEN	CAR			
2	60021500	2	VITE	VIS	SCHRAUBE	SCREW	TE 12 x 80 UNI 5737		
3	32183700	2	DISTANZIALE	ENTRETOISE	DISTANZSTÜCK	SPACER			
4	62010600	2	DADO	ECROU	MUTTER	NUT	M 12 x 1,75 AUTOBLOCC.		
5	40320100	1	TELAIO	CHASSIS	RAHMEN	FRAME			
6	60023000	6	VITE	VIS	SCHRAUBE	SCREW	TE 12 x 30 UNI 5739		
7	61005000	6	RONDELLA	RONDELLE	SCHEIBE	WASHER	PIANA Ø 12 UNI 6592		
8	62008300	2	DADO	ECROU	MUTTER	NUT	M 20 UNI 5588		
9	61005800	2	RONDELLA	RONDELLE	SCHEIBE	WASHER	PIANA Ø 20 UNI 6592		
10	68048300	1	TUBO	TUBE	ROHR	TUBE			
11	68048400	1	TUBO	TUBE	ROHR	TUBE			
12	39336800	1	SUPPORTO	SUPPORT	HALTERUNG	SUPPORT			
13	60023000	1	VITE	VIS	SCHRAUBE	SCREW	TE 12 x 30 UNI 5739		
14	62010600	1	DADO	ECROU	MUTTER	NUT	M 12 x 1,75 AUTOBLOCC.		
15	68123100	2	INNESTO FEMMINA	ENCLENCHEMENT FEMME	WEIB KUPPLUNG	FEMALE ENGAGEMENT			
16	68083800	1	CILINDRO	CYLINDRE	ZYLINDER	CYLINDER			
17	40121700	1	MANOVELLA	MANIVELLE	KURBEL	CRANK			
18	60023000	2	VITE	VIS	SCHRAUBE	SCREW	TE 12 x 30		
19	62014700	2	CHIOCCIOLA	ECROU EN CARACOLE	MUTTERSCHLOSS	LEAD NUT			
20	39337000	1	AGGANCI	CROCHET	HAKEN	HOOK			
21	40247000	1	VITE	VIS	SCHRAUBE	SCREW			
22	40246800	1	CHIOCCIOLA	ECROU EN CARACOLE	MUTTERSCHLOSS	LEAD NUT			
23	60036200	2	VITE	VIS	SCHRAUBE	SCREW	TE 8 x 35 UNI 5739		
24	62010200	2	DADO	ECROU	MUTTER	NUT	M 8 x 1,25 AUTOBLOCC.		
25	40219100	2	SLITTA	PATIN	STUTZKUF	SKID			
26	60023000	4	VITE	VIS	SCHRAUBE	SCREW	TE 12 x 30 UNI 5739		

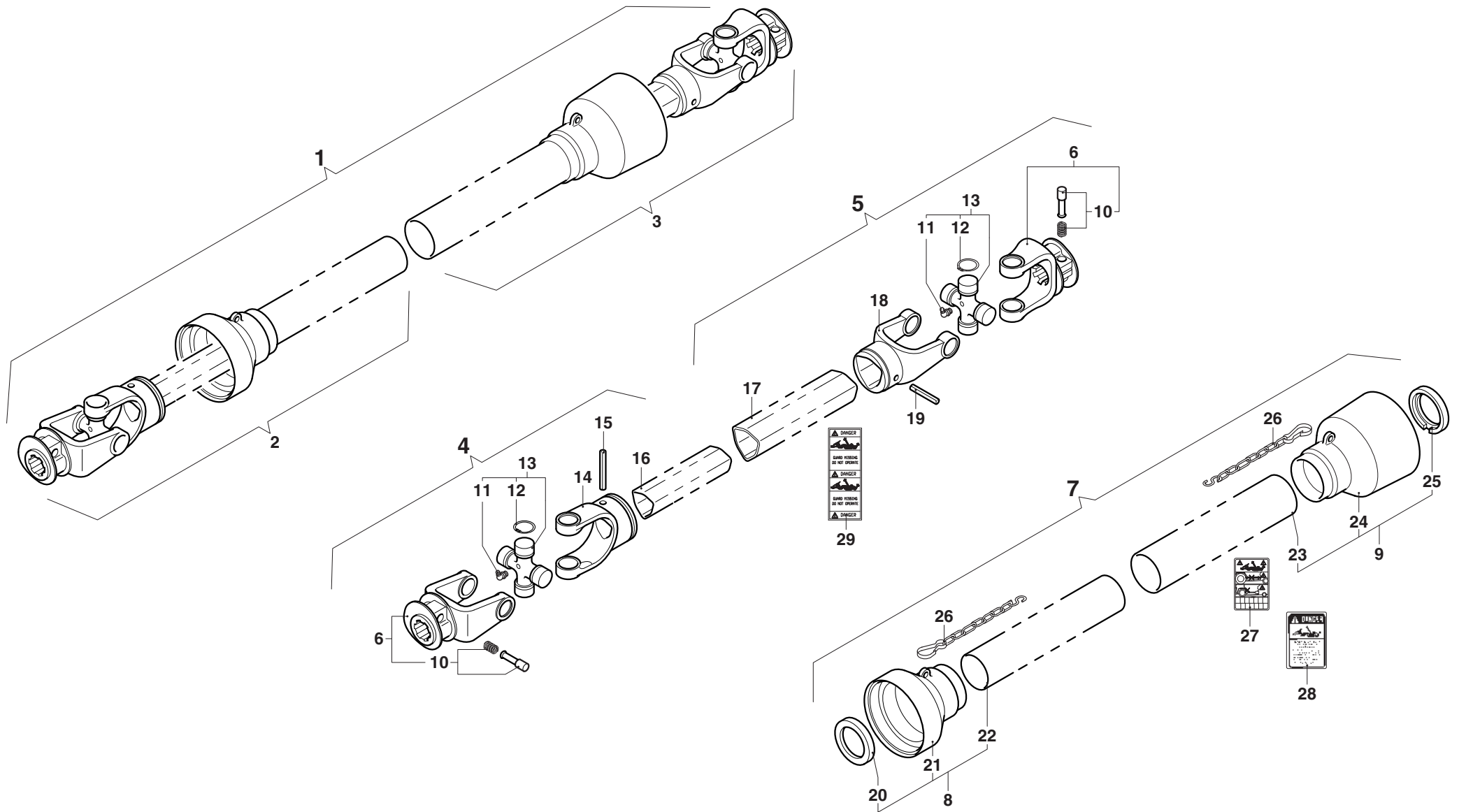



# MURATORI MT 40 F

TAV. 6.0

POS.	N° CODICE	Q.	DESCRIZIONE	DESIGNATION	BENENNUNG	DESCRIPTION	DESIGNAZIONE	Da matr. De nr. serie Vom Seriennr. From serial nr.	Fino matr. Jusqu'au nr. serie Bis Seriennr. Up to serial nr.
1	AB409SF	1	ALBERO CARDANICO COMPLETO	ARBRE A JOINTS DE CARDAN	KARDANWELLE	PTO SHAFT			
2	B4090B1	1	SEMIALBERO INTERNO	DEMI-ARBRE INTERIEUR	INNENHALBWELLE	INTERNAL HALF SHAFT			
3	B4090B2	1	SEMIALBERO ESTERNO	DEMI-ARBRE EXTERIEUR	AUSSENHALBWELLE	EXTERNAL HALF SHAFT			
4	B409001	1	SEMIALBERO INTERNO	DEMI-ARBRE INTERIEUR	INNENHALBWELLE	INTERNAL HALF SHAFT			
5	B409002	1	SEMIALBERO ESTERNO	DEMI-ARBRE EXTERIEUR	AUSSENHALBWELLE	EXTERNAL HALF SHAFT			
6	0800403	2	FORCELLA	FOURCHE	GABEL	YOKE			
7	083B04090	1	PROTEZIONE	PROTECTION	SCHUTZ	GUARD			
8	083B040901	1	PROTEZIONE INTERNA	PROTECTION INTERIEURE	INNENSCHUTZ	INTERNAL GUARD			
9	083B040902	1	PROTEZIONE ESTERNA	PROTECTION EXTERIEURE	AUSSENSCHUTZ	EXTERNAL GUARD			
10	0986014047	2	PULSANTE	BOUTON	DRUCKKNOPF	PUSH BOTTON			
11	09840081002	2	INGRASSATORE	GRAISSEUR	SCHMIERNIPPEL	GREASE FITTING			
12	09802027	8	ANELLO ELASTICO	ARRETOIR	SPANNRING	SNAP-RING			
13	08204	2	CROCIERA	CROISILLON	KREUZSTÜCK	SPIDER			
14	08004011	1	FORCELLA	FOURCHE	GABEL	YOKE			
15	098700855	1	SPINA ELASTICA	GOUPILLE ELASTIQUE	SPANNSTIFT	ELASTIC PIN			
16	09881364100	1	TUBO INTERNO	TUBE INTERIEUR	INNENROHR	INTERNAL TUBE			
17	09881433100	1	TUBO ESTERNO	TUBE EXTERIEUR	AUSSENROHR	EXTERNAL TUBE			
18	08004021	1	FORCELLA	FOURCHE	GABEL	YOKE			
19	098700860	1	SPINA ELASTICA	GOUPILLE ELASTIQUE	SPANNSTIFT	ELASTIC PIN			
20	0265240008	1	GHIERA	FRETTE	NUTMUTTER	RING NUT			
21	0256040425	1	CUFFIA	CAPOUCHON	HAUBE	GUARD			
22	0988961B4090	1	TUBO INTERNO	TUBE INTERIEUR	INNENROHR	INTERNAL TUBE			
23	0988966B4090	1	TUBO ESTERNO	TUBE EXTERIEUR	AUSSENROHR	EXTERNAL TUBE			
24	0256040424	1	CUFFIA	CAPOUCHON	HAUBE	GUARD			
25	0265240007	1	GHIERA	FRETTE	NUTMUTTER	RING NUT			

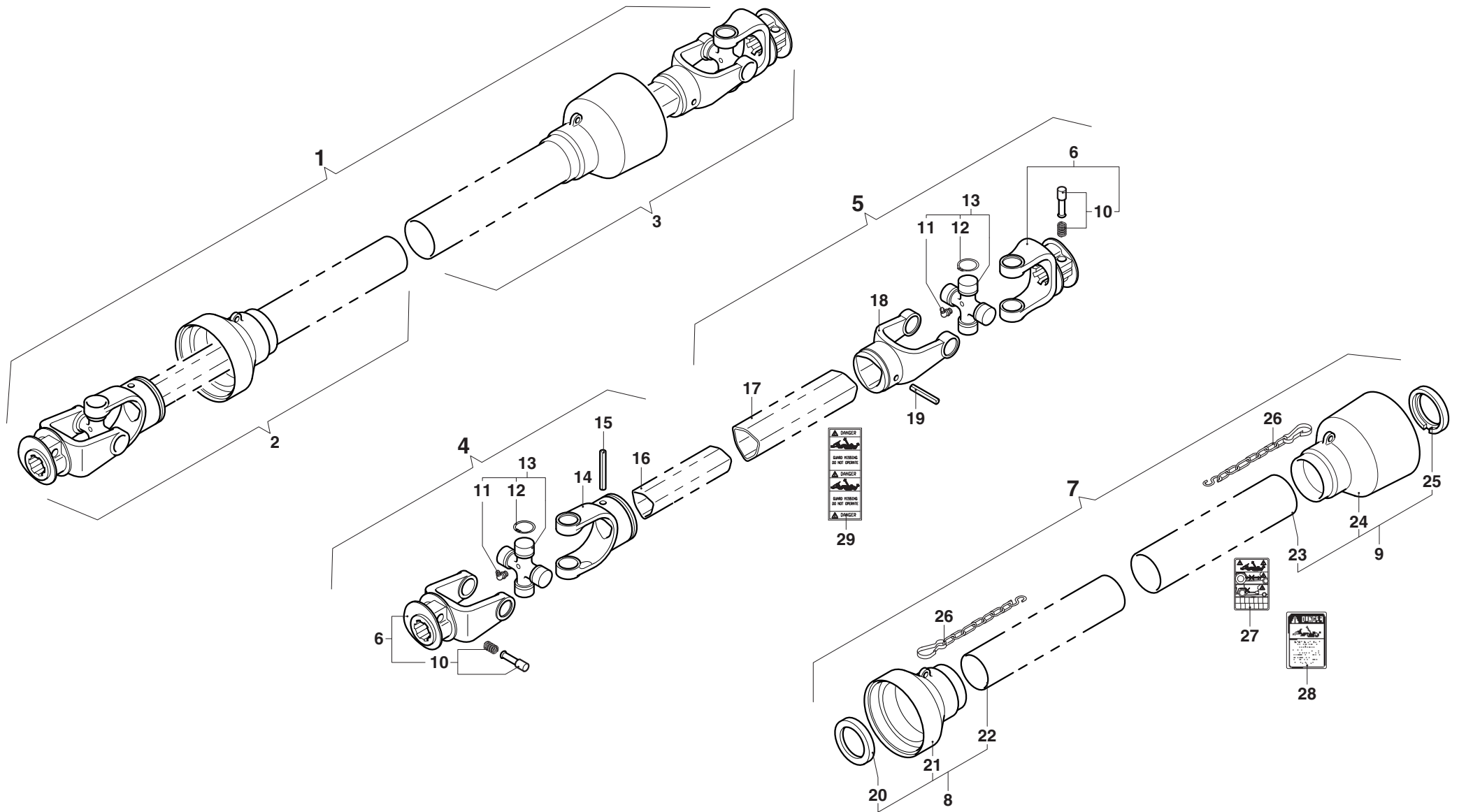









**MURATORI S.p.A.**

Via Pavarello, 21 - 41051 Castelnuovo Rangone (MO) Italy - Tel. 059.5330611 Fax 059.537259

[www.muratoriequip.it](http://www.muratoriequip.it) [info@muratoriequip.it](mailto:info@muratoriequip.it)

Capitale sociale Euro 480.000 interamente versato

Registro Imprese di Modena

Codice fiscale e numero d'iscrizione: 00708860366

 **Miniwerk**tuingshop