



MURATORI

**TIPO-TYPE-TYP
MR ID**

CATALOGO RICAMBI
Catalogue Pièces Detachées
Ersatzteilkatalog
Spare Parts Catalogue
Catálogo Recambios

EDIZIONE 10/2017



NORME PER LE ORDINAZIONI - COMMANDES/NORMES - BESTELLNORMEN - HOW TO ORDER

MR ID

Per ordinare parti di ricambio specificare:

- tipo e matricola della macchina (apposti sulla macchina o sui documenti di acquisto);
- numero del riferimento del pezzo nel disegno (Pos.), numero della tavola (Tav.) e numero di codice

N.B.: le indicazioni destro o sinistro vengono date guardando la macchina da dietro.

Pour les commandes de pièces de rechange veuillez spécifier:

- *type et numéro de série de la machine (indiqués sur la machine et sur le bon d'achat);*
- *numéro de référence du pièce sur le plan (Pos.), numéro du plan (Tav.) et numéro de code (codice)*

N.B.: *les indications droite ou gauche sont données en regardant la machine par derrière.*

Zum Bestellen von Ersatzteilen folgendes angeben:

- Typ und Serien-Nr. der Maschine (zu finden auf der Maschine oder der Einkaufspapieren);
- Bezug-Nr. des Ersatzteils auf der Zeichnung (Pos.), Zeichnungsnummer (Tav.) und Kodenummer (codice)

N.B.: die Angaben rechts und links verstehen sich so, dass man hinter der Maschine steht.

When ordering spare parts specify:

- *machine type and serial number (found on the machine or on the purchasing documents);*
- *reference number of the part on the relative drawing (Pos.) number of the drawing (Tav.) and part number (codice)*

N.B.: *right-hand or left-hand indications are made by viewing the machine from the rear.*

TAV. 1.0

GRUPPO TELAIO
ENSEMBLE CHASSIS
SATZ FÜR RAHMEN
KIT FOR FRAME

TAV. 2.0

TRASMISSIONE ROTORI
TRANSMISSION ROTORS
ROTOREN ANTRIEB
ROTORS TRANSMISSION

TAV. 3.0

GRUPPO MOTORE IDRAULICO
GROUPE MOTEUR HYDRAULIQUE
HYDRAULIKMOTORGRUPPE
HYDRAULIC MOTOR GROUP

TAV. 4.0

IMPIANTO IDRAULICO (17 cc)
INSTALLATION HYDRAULIQUE
HYDRAULISCHEANLAGE
HYDRAULIC SYSTEM

TAV. 4.1

IMPIANTO IDRAULICO (26 cc) - (40 l)
INSTALLATION HYDRAULIQUE
HYDRAULISCHEANLAGE
HYDRAULIC SYSTEM

TAV. 4.2

IMPIANTO IDRAULICO (36 cc) - (55 l)
INSTALLATION HYDRAULIQUE
HYDRAULISCHEANLAGE
HYDRAULIC SYSTEM

TAV. 4.3

KIT VALVOLA PORTATA COMPENSATA (OPZIONALE) (17-20-26 cc)
KIT VALVE DE PRIORITÉ (OPTION)
KIT AUSGLEICHVENTIL (ZUBEHÖR)
KIT FLOW SHUTTER VALVE (OPTIONAL)

TAV. 4.4

KIT VALVOLA PORTATA COMPENSATA (OPZIONALE) (36 cc)
KIT VALVE DE PRIORITÉ (OPTION)
KIT AUSGLEICHVENTIL (ZUBEHÖR)
KIT FLOW SHUTTER VALVE (OPTIONAL)

TAV. 5.0

CONVOGLIAMENTO LATERALE
EJECTION LATERAL
SEITLICH AUSWURF
SIDE DISCHARGE

TAV. 6.0

CONVOGLIAMENTO POSTERIORE
EJECTION ARRIERE
HECK AUSWURF
REAR DISCHARGE

TAV. 7.0

VERSIONE "MULCHING"
VERSION "MULCHING"
MULCHING" VERSION
"MULCHING" VERSION

TAV. 8.0

ATTACCO FRONTALE
ATTELAGE FRONTAL
FRONTANBAU
FRONT LINKAGE

TAV. 8.1

ATTACCO BASE
ATTELAGE BASE
BASISANBAU
FRONT BASE

TAV. 8.2

ATTACCO MULTIFUNZIONE
CONNEXION MULTI-TASKING
MULTITASKING ANSCHLUSS
MULTI-TASKING LINKAGE

TAV. 8.3

ATTACCO "MUSTANG"
CONNEXION "MUSTANG"
"MUSTANG" ANSCHLUSS
"MUSTANG" LINKAGE

TAV. 8.4

ATTACCO "TORO DINGO"
CONNEXION "TORO DINGO"
"TORO DINGO" ANSCHLUSS
"TORO DINGO" LINKAGE

TAV. 8.5

ATTACCO "WEIDEMANN"
CONNEXION "WEIDEMANN"
"WEIDEMANN" ANSCHLUSS
"WEIDEMANN" LINKAGE

TAV. 8.6

ATTACCO "KNIKMOPS"
CONNEXION "KNIKMOPS"
"KNIKMOPS" ANSCHLUSS
"KNIKMOPS" LINKAGE

TAV. 8.7

ATTACCO "TOBROCO GIANT"
CONNEXION "TOBROCO GIANT"
"TOBROCO GIANT" ANSCHLUSS
"TOBROCO GIANT" LINKAGE

TAV. 8.8

ATTACCO "SCHAEFFER"
CONNEXION "SCHAEFFER"
"SCHAEFFER" ANSCHLUSS
"SCHAEFFER" LINKAGE

TAV. 8.9

ATTACCO "SCHAEFFER" (B)
CONNEXION "SCHAEFFER" (B)
"SCHAEFFER" (B) ANSCHLUSS
"SCHAEFFER" (B) LINKAGE

TAV. 8.10

ATTACCO "SCHAEFFER" (NEW)
CONNEXION "SCHAEFFER" (NEW)
"SCHAEFFER" (NEW) ANSCHLUSS
"SCHAEFFER" (NEW) LINKAGE

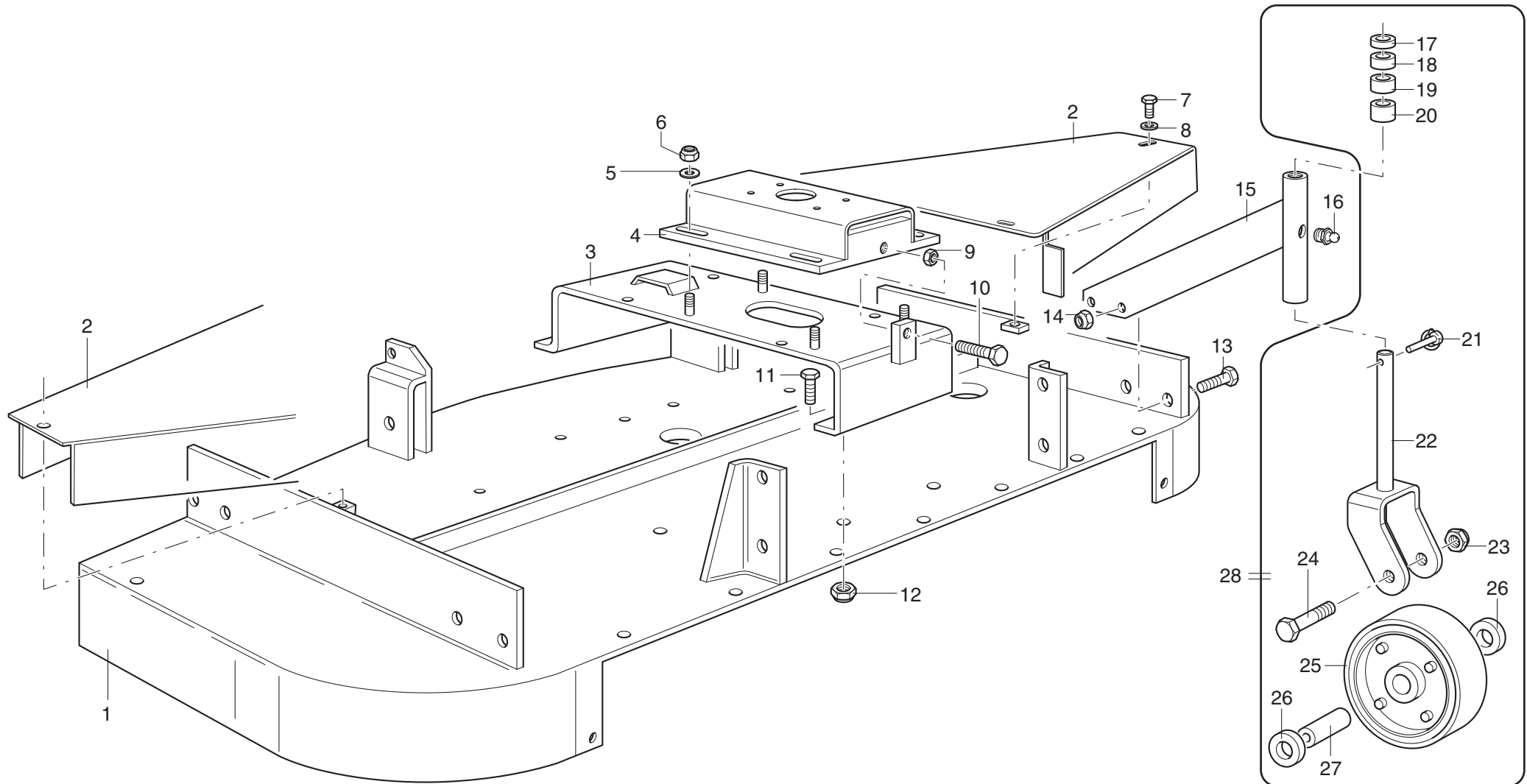

MURATORI MR ID

TAV. 1.0

POS.	N° CODICE	Q.	DESCRIZIONE	DESIGNATION	BENENNUNG	DESCRIPTION	DESIGNAZIONE	Da matr. De nr. serie Vom Seriennr. From serial nr.	Fino matr. Jusqu'au nr. serie Bis Seriennr. Up to serial nr.
1	41117400	1	TELAIO	CHASSIS	RAHMEN	FRAME	120		130936
1	41111300	1	TELAIO	CHASSIS	RAHMEN	FRAME	120	130937	
1	41123000	1	TELAIO	CHASSIS	RAHMEN	FRAME	135		132146
1	41122800	1	TELAIO	CHASSIS	RAHMEN	FRAME	135	132147	
1	41117500	1	TELAIO	CHASSIS	RAHMEN	FRAME	150		130936
1	41111400	1	TELAIO	CHASSIS	RAHMEN	FRAME	150	130937	
1	41117600	1	TELAIO	CHASSIS	RAHMEN	FRAME	180		131810
1	41111500	1	TELAIO	CHASSIS	RAHMEN	FRAME	180	131811	
1	41123100	1	TELAIO	CHASSIS	RAHMEN	FRAME	210		131216
1	41122900	1	TELAIO	CHASSIS	RAHMEN	FRAME	210	131217	
2	39259200	2	CARTER	CARTER	KETTENKASTEN	CASING	120		
2	39305000	2	CARTER	CARTER	KETTENKASTEN	CASING	135		
2	39286700	2	CARTER	CARTER	KETTENKASTEN	CASING	150		
2	39286800	2	CARTER	CARTER	KETTENKASTEN	CASING	180		
2	39305100	2	CARTER	CARTER	KETTENKASTEN	CASING	210		
3	40233900	1	SUPPORTO	SUPPORT	HALTER	SUPPORT	120		
3	40234000	1	SUPPORTO	SUPPORT	HALTER	SUPPORT	150-180		
4	40247700	1	CONTROPIASTRA	CONTRE-PLAQUE	GEGENPLATTE	COUNTER PLATE			
5	61004900	4	RONDELLA	RONDELLE	SCHEIBE	WASHER	PIANA Ø 10 UNI 6592		
6	62010400	4	DADO	ECROU	MUTTER	NUT	M 10x1,5 AUTOBLOCC.		
7	60024600	6	VITE	VIS	SCHRAUBE	SCREW	TE 8x12 UNI 5739		
8	61004700	6	RONDELLA	RONDELLE	SCHEIBE	WASHER	PIANA Ø 8 UNI 6592		
9	62007000	2	DADO	ECROU	MUTTER	NUT	M 10x1,5 UNI 5588		
10	60030200	1	VITE	VIS	SCHRAUBE	SCREW	TE 10x80 UNI 5739		
11	60017900	5	VITE	VIS	SCHRAUBE	SCREW	TE 10 x 25 UNI 5739 8.8 ZNT		
12	62010400	2	DADO	ECROU	MUTTER	NUT	M 10x1,5 AUTOBLOCC.		

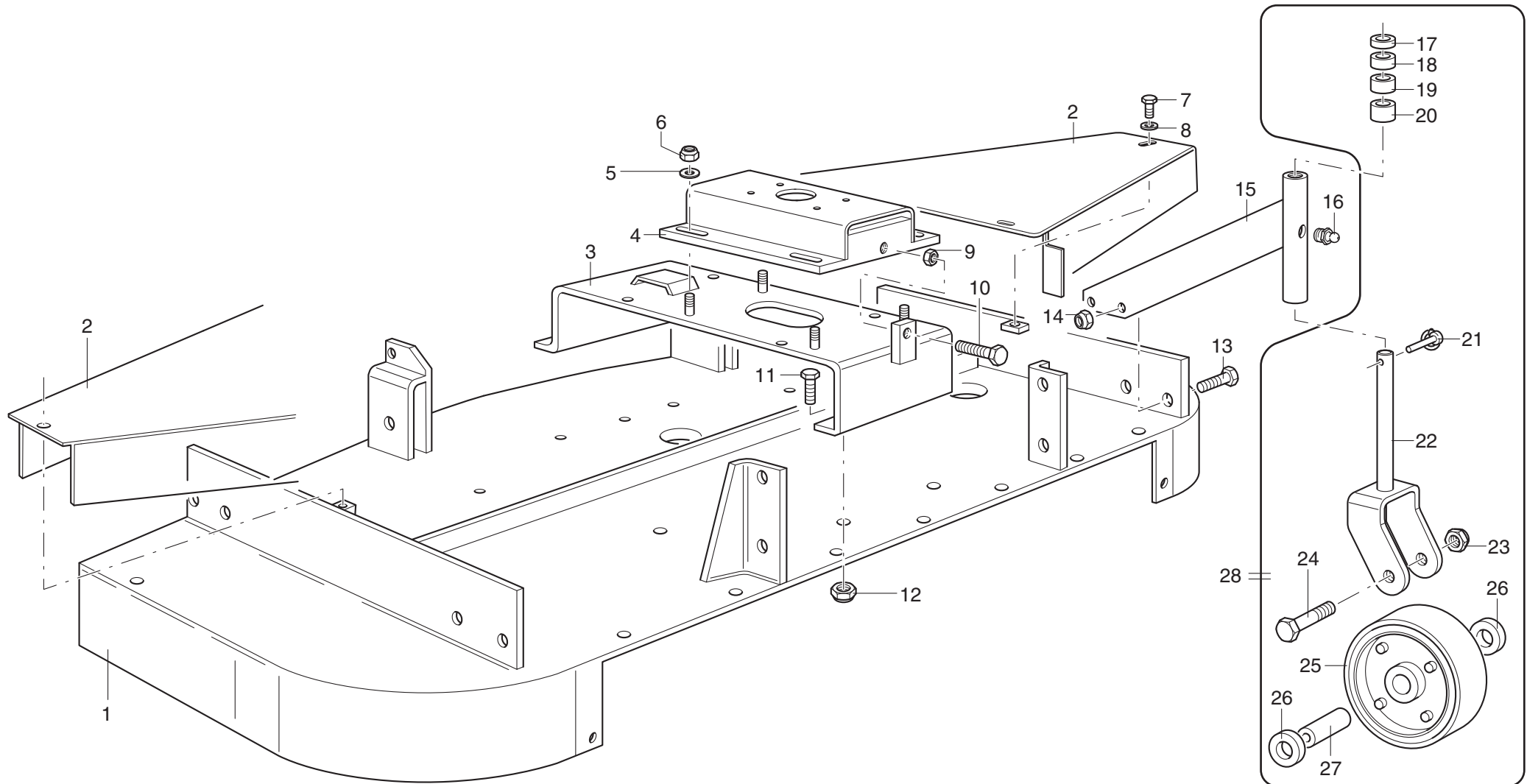

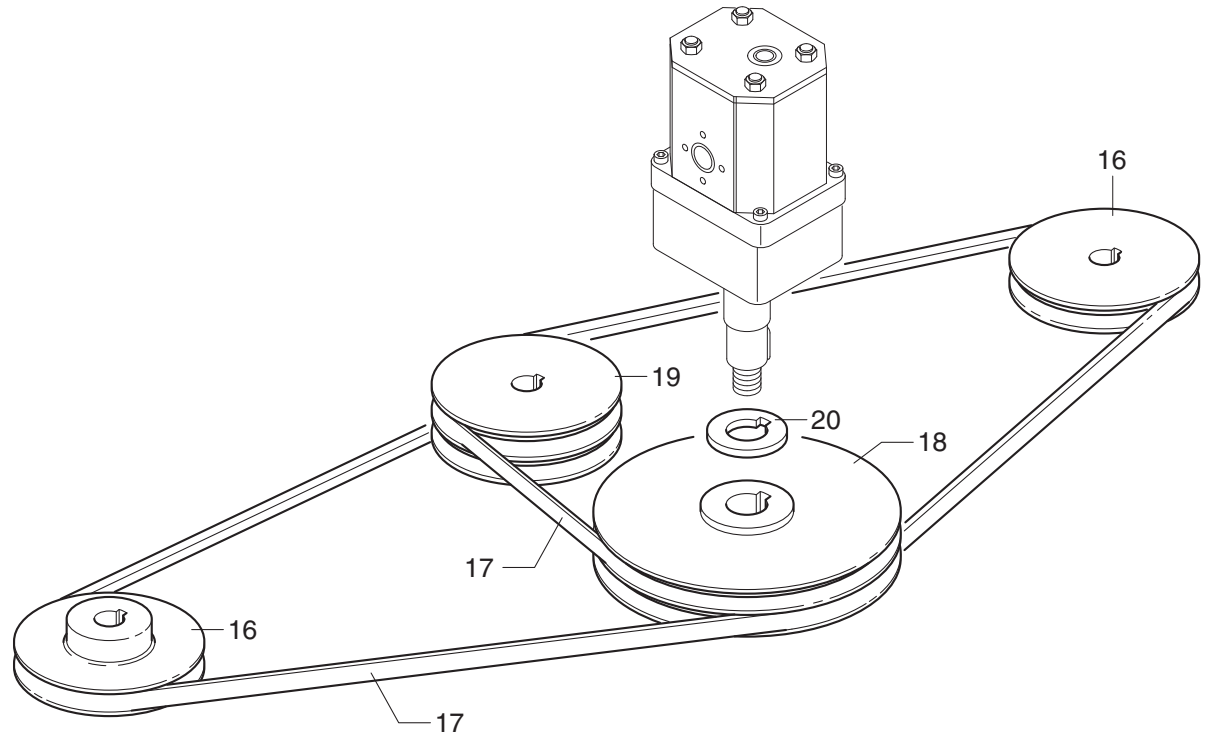
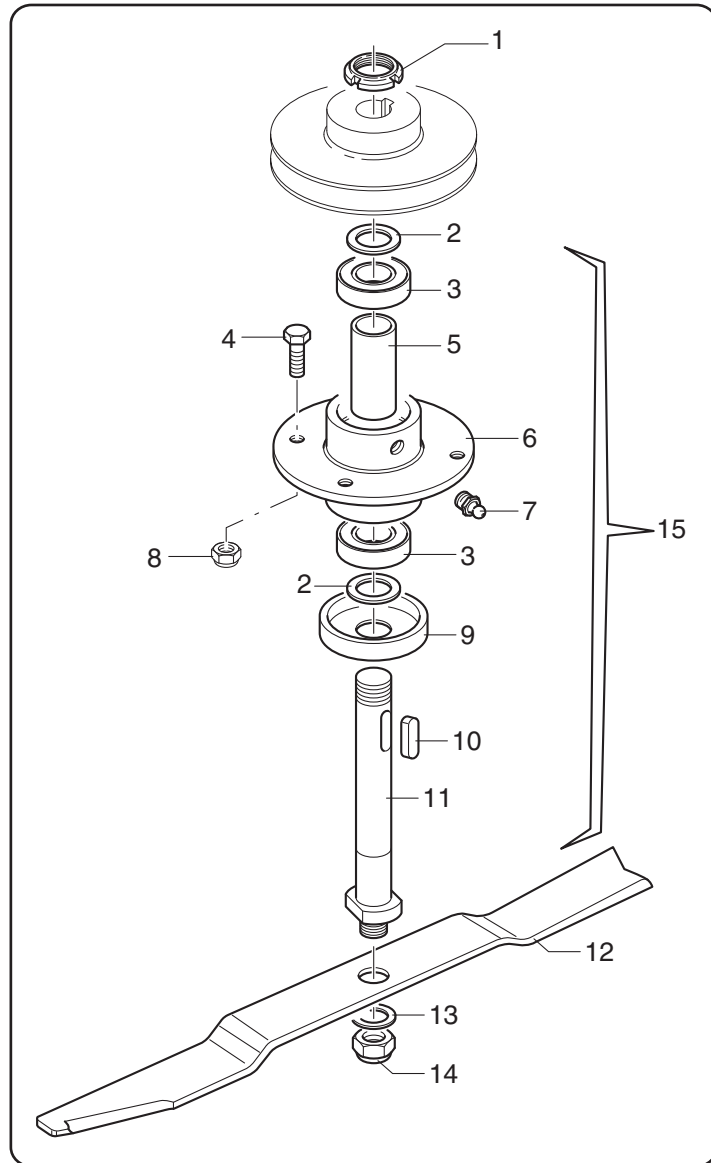

MURATORI MR ID

TAV. 2.0

POS.	N° CODICE	Q.	DESCRIZIONE	DESIGNATION	BENENNUNG	DESCRIPTION	DESIGNAZIONE	Da matr. De nr. serie Vom Seriennr. From serial nr.	Fino matr. Jusqu'au nr. serie Bis Seriennr. Up to serial nr.
1	62001200	3	GHIERA	FRETTE	NUTMUTTER	RING NUT	M 25 x 1.5 AUTOBLOCC.		
2	32174100	6	SPESSORE	EPAISSEUR	BEILAGERING	SPACER			
3	67016600	6	CUSCINETTO	ROULEMENT	LAGER	BEARING	6205 RS		
4	60021300	12	VITE	VIS	SCHRAUBE	SCREW	TE 10 x 30 UNI 5739 8.8 ZNT		
5	32174000	3	DISTANZIALE	ENTRETOISE	DISTANZSTÜCK	SPACER			
6	40234100	3	SUPPORTO	SUPPORT	HALTERUNG	SUPPORT			
7	64001800	3	INGRASSATORE	GRAISSEUR	SCHMIERNIPPEL	GREASE FITTING	M 10 x 1 DIRITTO		
8	62010400	12	DADO	ECROU	MUTTER	NUT	M 10 x 1.5 AUTOBLOCC.		
9	39261100	3	PROTEZIONE	PROTECTION	SCHUTZ	GUARD			
10	65001100	3	LINGUETTA	CLAVETTE	FEDER	KEY	8 x 7 x 30 UNI 6604		
11	31078600	3	ALBERO	ARBRE	WELLE	SHAFT			
12	12017700	3	LAMA	LAME DE COUPE	SCHNEIDKANTE	BLADE	120		
12	12021200	3	LAMA	LAME DE COUPE	SCHNEIDKANTE	BLADE	135		
12	12017800	3	LAMA	LAME DE COUPE	SCHNEIDKANTE	BLADE	150		
12	12017900	3	LAMA	LAME DE COUPE	SCHNEIDKANTE	BLADE	180		
12	12021300	3	LAMA	LAME DE COUPE	SCHNEIDKANTE	BLADE	210		
13	39077800	3	RONDELLA	RONDELLE	SCHEIBE	WASHER	PIANA Øi 19 Øe 50 SP5		
14	62011100	6	DADO	ECROU	MUTTER	NUT	M 18 x 1.5 AUTOBLOCC.		
15	45115100		MOZZO COMPLETO	ENSEMBLE MOYEU	SATZ NABE	SPINDLE ASSEMBLY			
16	68086600	2	PULEGGIA	POULIE	RIEMENSCHLEIBE	PULLEY	120		
16	68112500	2	PULEGGIA	POULIE	RIEMENSCHLEIBE	PULLEY	135		
16	68086700	2	PULEGGIA	POULIE	RIEMENSCHLEIBE	PULLEY	150-180-210		
17	68083500	2	CINGHIA	COURROIE	KEILRIEMEN	BELT	120		
17	68113000	2	CINGHIA	COURROIE	KEILRIEMEN	BELT	135		
17	68086900	2	CINGHIA	COURROIE	KEILRIEMEN	BELT	150		
17	68087000	2	CINGHIA	COURROIE	KEILRIEMEN	BELT	180-210		

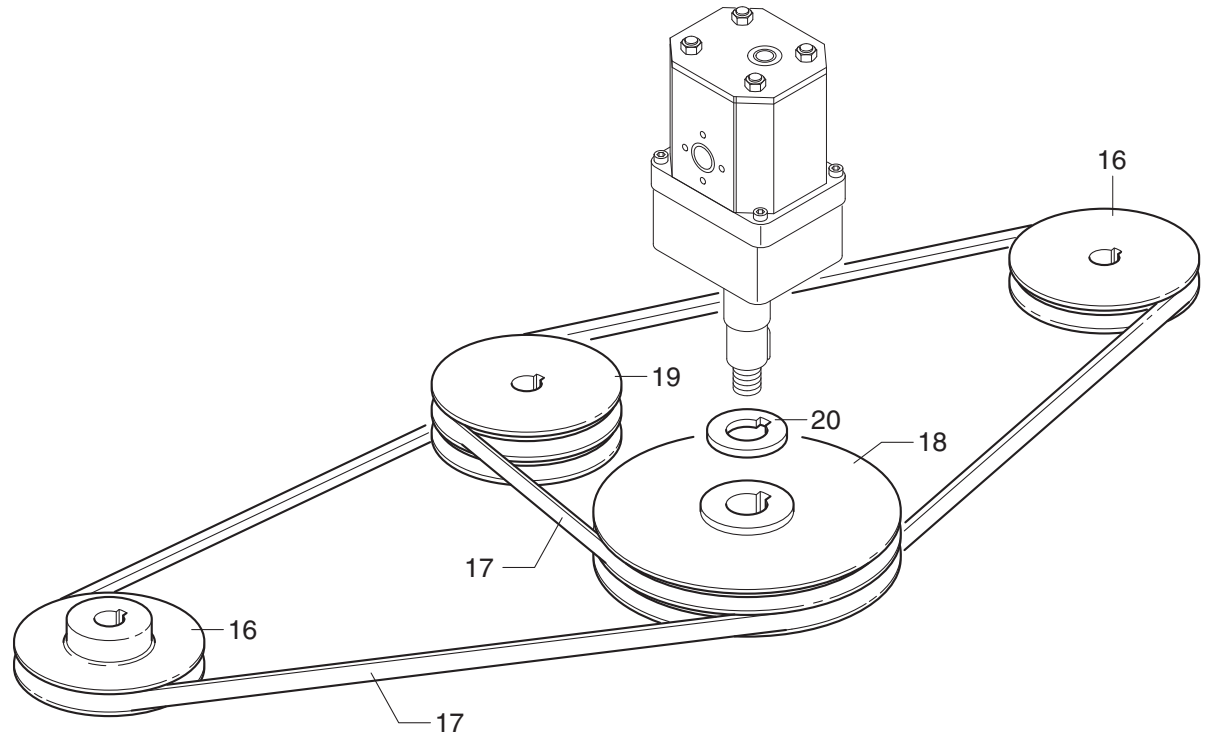
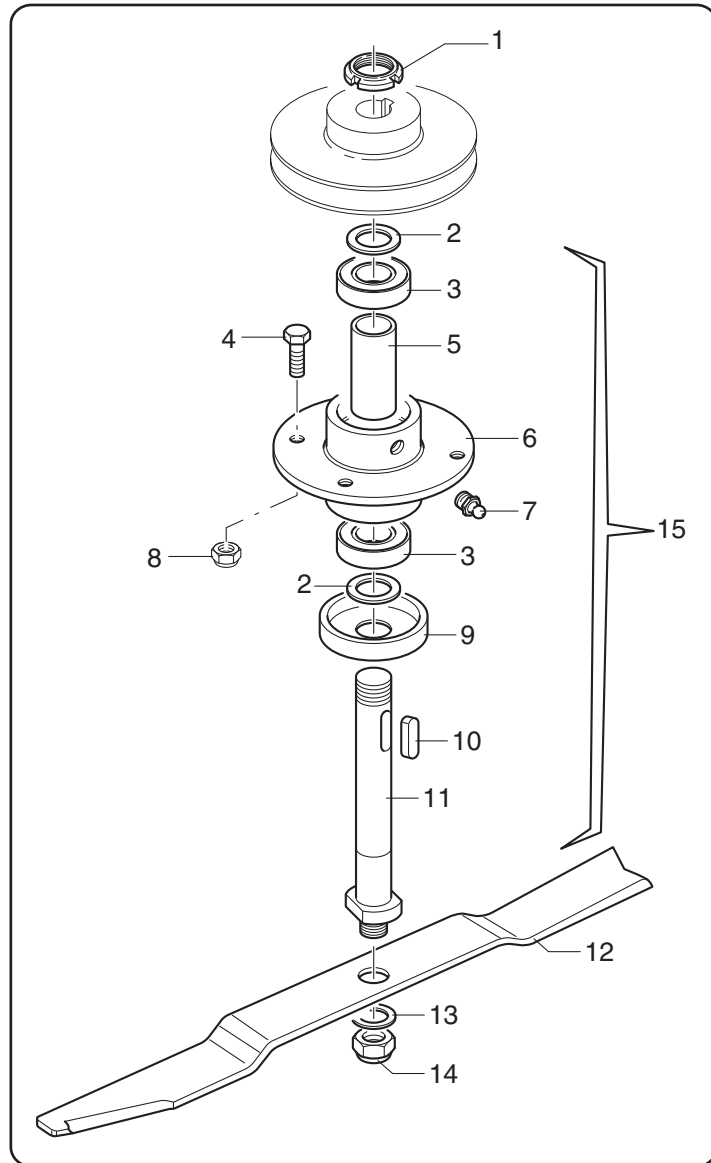

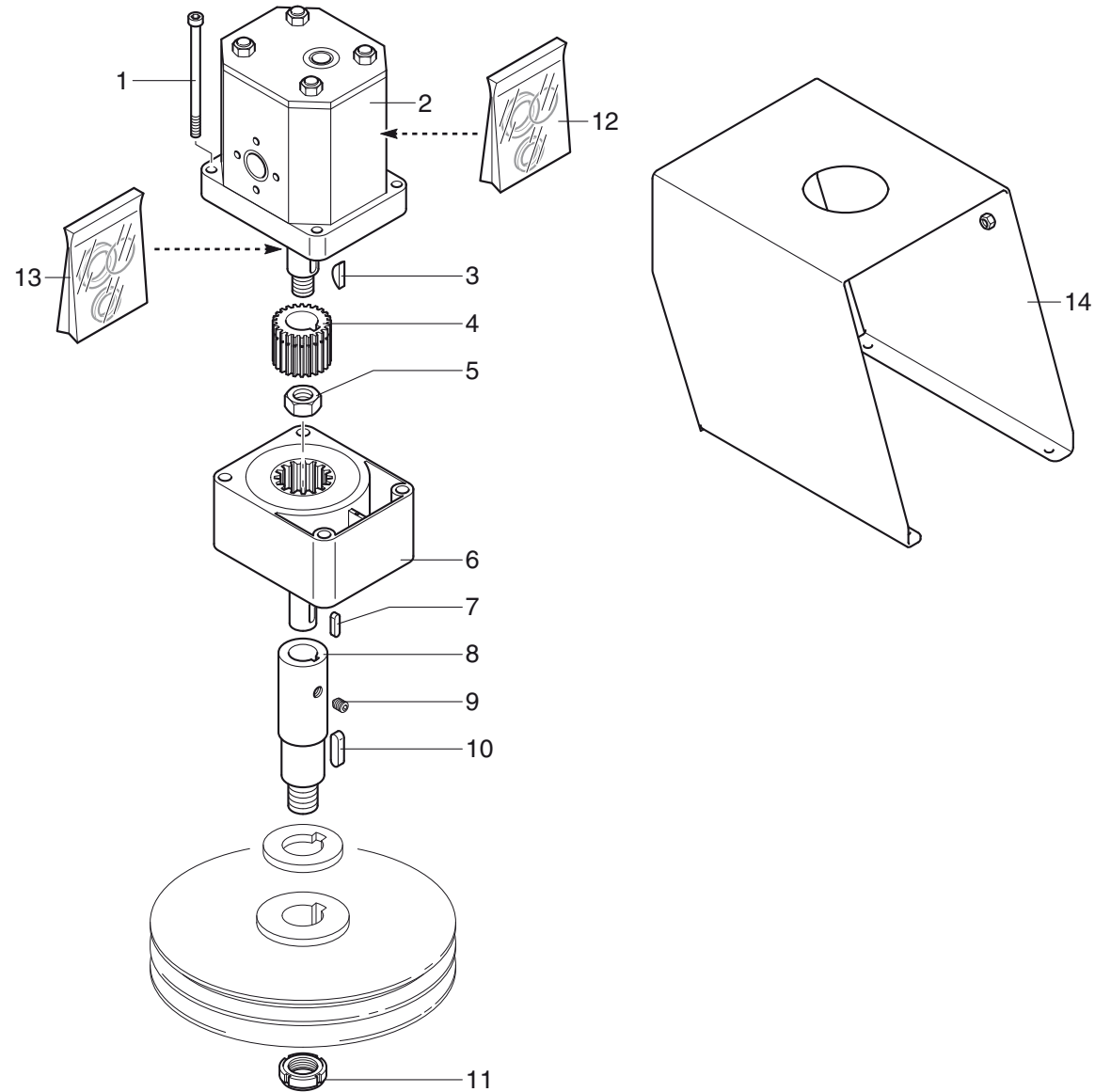

MURATORI MR ID

TAV. 3.0

POS.	N° CODICE	Q.	DESCRIZIONE	DESIGNATION	BENENNUNG	DESCRIPTION	DESIGNAZIONE	Da matr. De nr. serie Vom Seriennr. From serial nr.	Fino matr. Jusqu'au nr. serie Bis Seriennr. Up to serial nr.
1	60042900	4	VITE	VIS	SCHRAUBE	SCREW	TCEI 8x90 UNI 5931		
2	68097900	1	MOTORE IDRAULICO	MOTEUR HYDRAULIQUE	HYDRAULIKMOTOR	HYDRAULIC MOTOR	120-135 (17 cc)		
2	68089400	1	MOTORE IDRAULICO	MOTEUR HYDRAULIQUE	HYDRAULIKMOTOR	HYDRAULIC MOTOR	150-180-210 (20 cc)		135744
2	68097700	1	MOTORE IDRAULICO	MOTEUR HYDRAULIQUE	HYDRAULIKMOTOR	HYDRAULIC MOTOR	(26 cc)		135953
2	68129300	1	MOTORE IDRAULICO	MOTEUR HYDRAULIQUE	HYDRAULIKMOTOR	HYDRAULIC MOTOR	(36 cc)		135797
2	68133500	1	MOTORE IDRAULICO	MOTEUR HYDRAULIQUE	HYDRAULIKMOTOR	HYDRAULIC MOTOR	150 - 180 - 210 (20 cc)	135745	
2	68133600	1	MOTORE IDRAULICO	MOTEUR HYDRAULIQUE	HYDRAULIKMOTOR	HYDRAULIC MOTOR	(26 cc)	135954	
2	68135000	1	MOTORE IDRAULICO	MOTEUR HYDRAULIQUE	HYDRAULIKMOTOR	HYDRAULIC MOTOR	(36 cc)	135798	
3	65003000	1	LINGUETTA	CLAVETTE	FEDER	KEY			
4	31082600	1	SEMIGIUNTO	DEMI-JOINT	HALBGELENK	HALF COUPLING			
4	31090200	1	SEMIGIUNTO	DEMI-JOINT	HALBGELENK	HALF COUPLING	(26 cc - 36 cc)		
5	62006100	1	DADO	ECROU	MUTTER	NUT	M 12x1,5 UNI 5588		
6	68089500	1	SUPPORTO	SUPPORT	HALTERUNG	SUPPORT			
6	68129400	1	SUPPORTO	SUPPORT	HALTERUNG	SUPPORT	(26 cc - 36 cc)		
7	65003200	1	LINGUETTA	CLAVETTE	FEDER	KEY	6 x 6 x 40		
8	31082500	1	ALBERO	ARBRE	WELLE	SHAFT			
9	60038800	1	VITE	VIS	SCHRAUBE	SCREW	STEI 8x10 UNI 5927		
10	65000200	1	LINGUETTA	CLAVETTE	FEDER	KEY	10 x 8 x 35		
11	62001200	2	GHIERA	FRETTE	NUTMUTTER	RING NUT	M 25 x 1,5 AUTOBLOCC.		
12	66019800	1	KIT GUARNIZIONI MOTORE	KIT GARNITURES MOTEUR	MOTOR SATZ DICHTUNGEN	MOTOR GASKETS KIT	(17-20 cc)		
12	66019900	1	KIT GUARNIZIONI MOTORE	KIT GARNITURES MOTEUR	MOTOR SATZ DICHTUNGEN	MOTOR GASKETS KIT GASKETS KIT	(26 cc)		
13	66020000	1	KIT GUARNIZIONI ALBERO - FLANGIA	KIT GARNITURES ARBRE - BRIDE	WELLE - FLANSCH SATZ DICHTUNGEN	SHAFT - FLANGE GASKETS KIT	(17-20 cc)		
13	66020100	1	KIT GUARNIZIONI ALBERO - FLANGIA	KIT GARNITURES ARBRE - BRIDE	WELLE - FLANSCH SATZ DICHTUNGEN	SHAFT - FLANGE GASKETS KIT	(26 cc)		
14	40333800	1	PROTEZIONE	PROTECTION	SCHUTZ	GUARD			

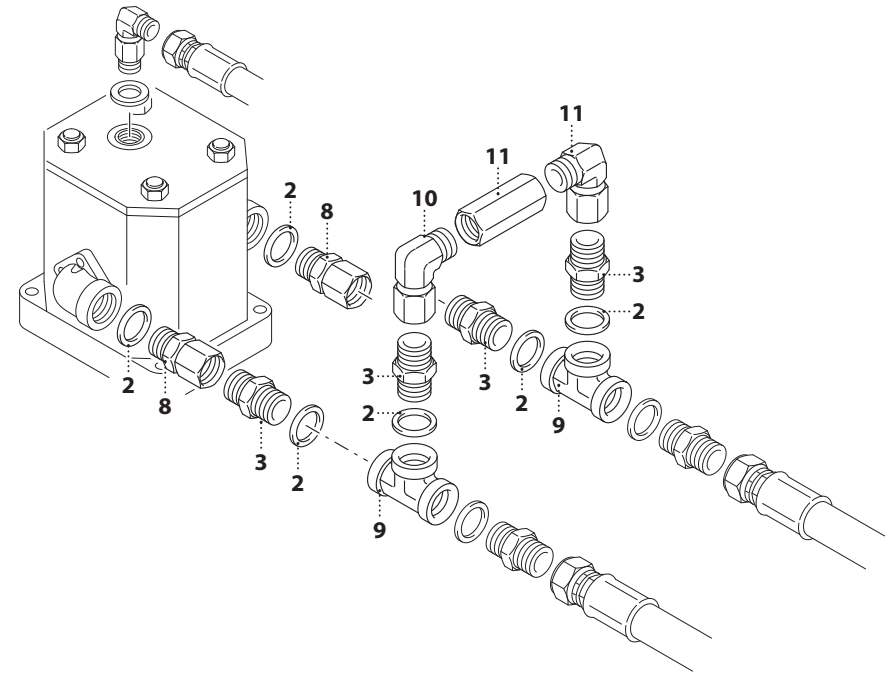
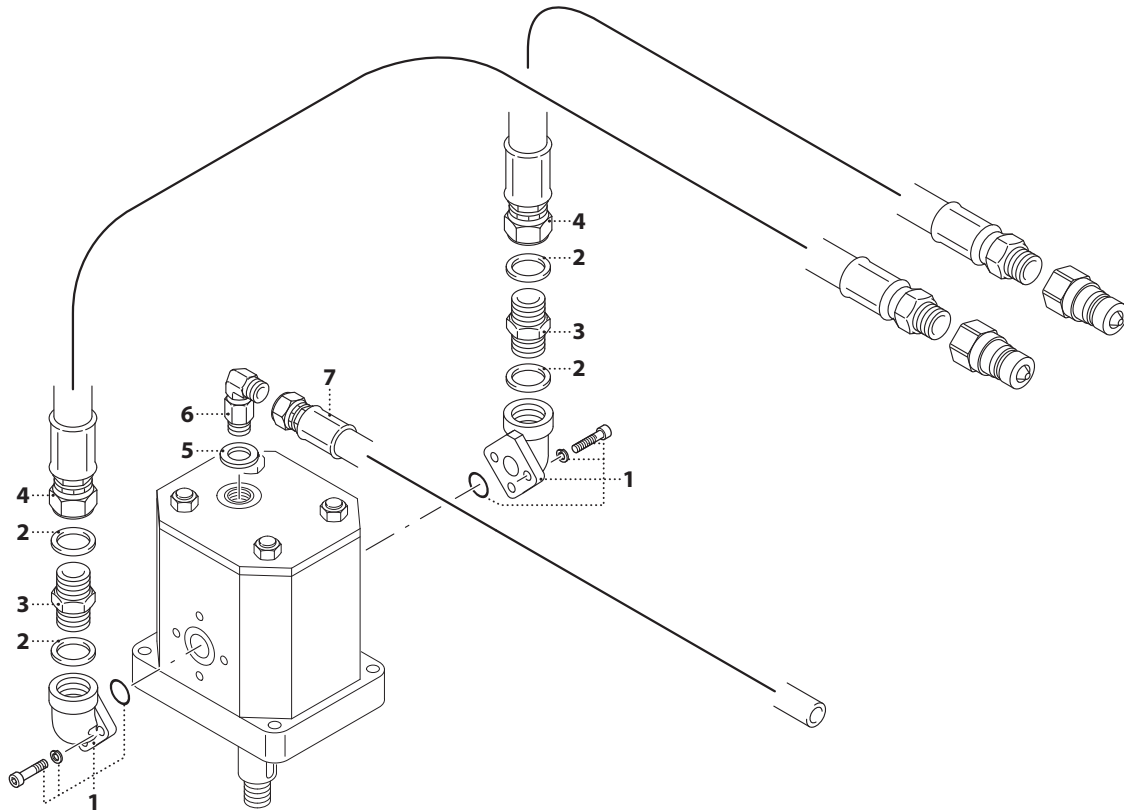

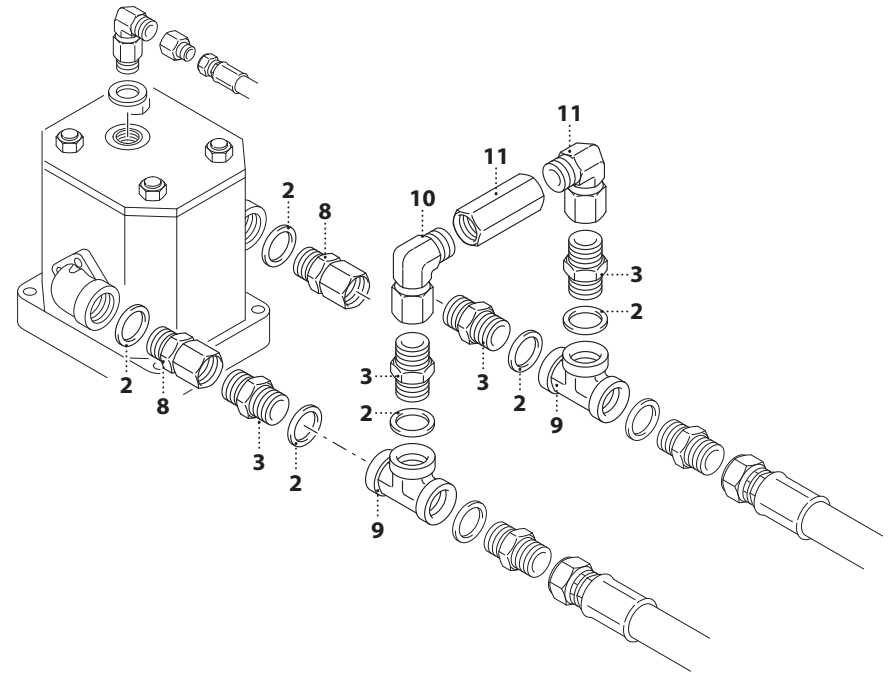
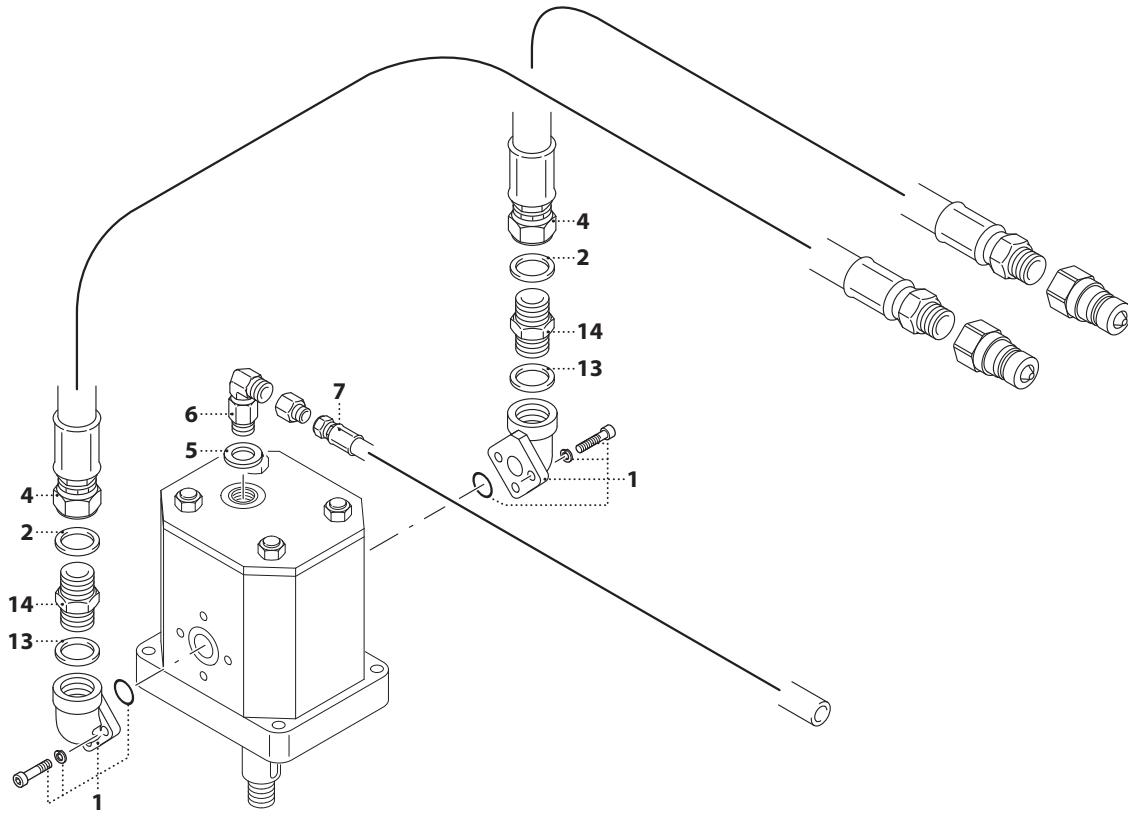

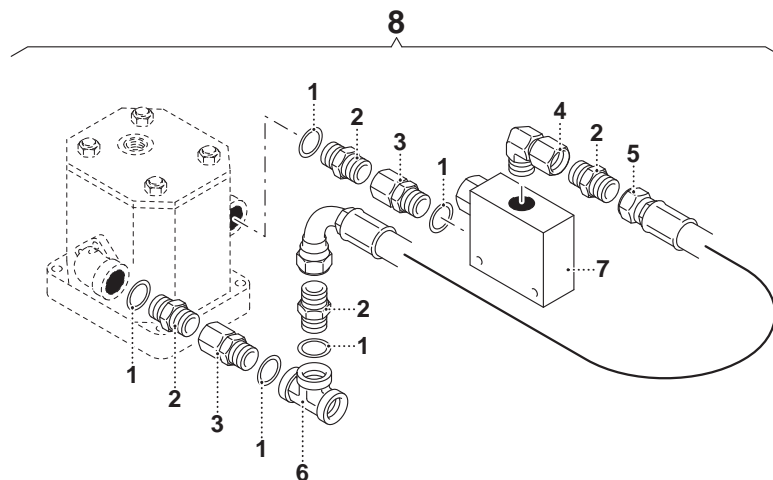

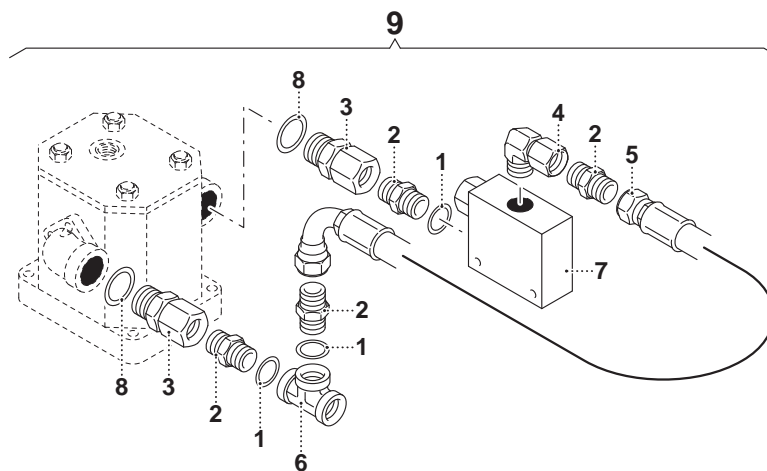

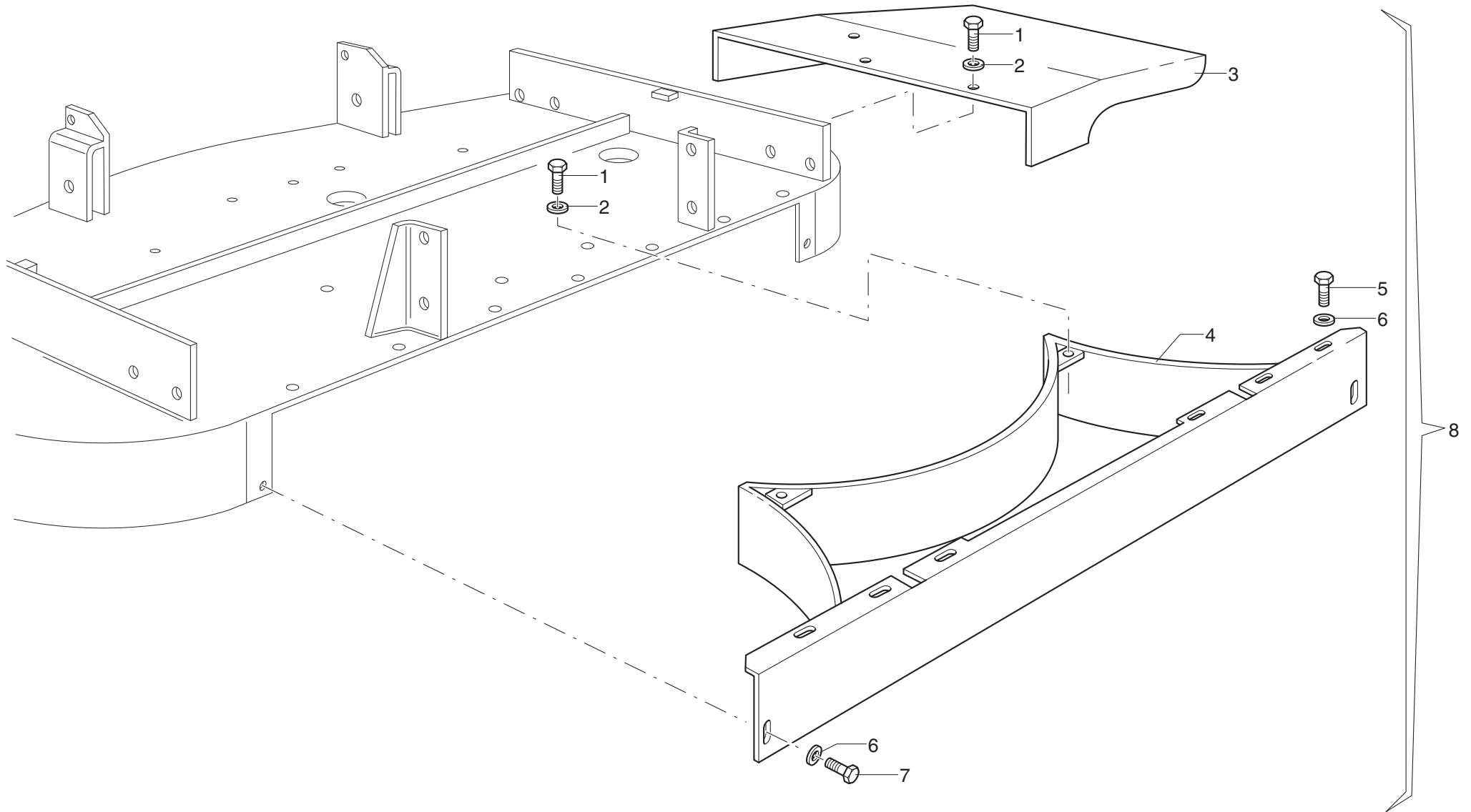

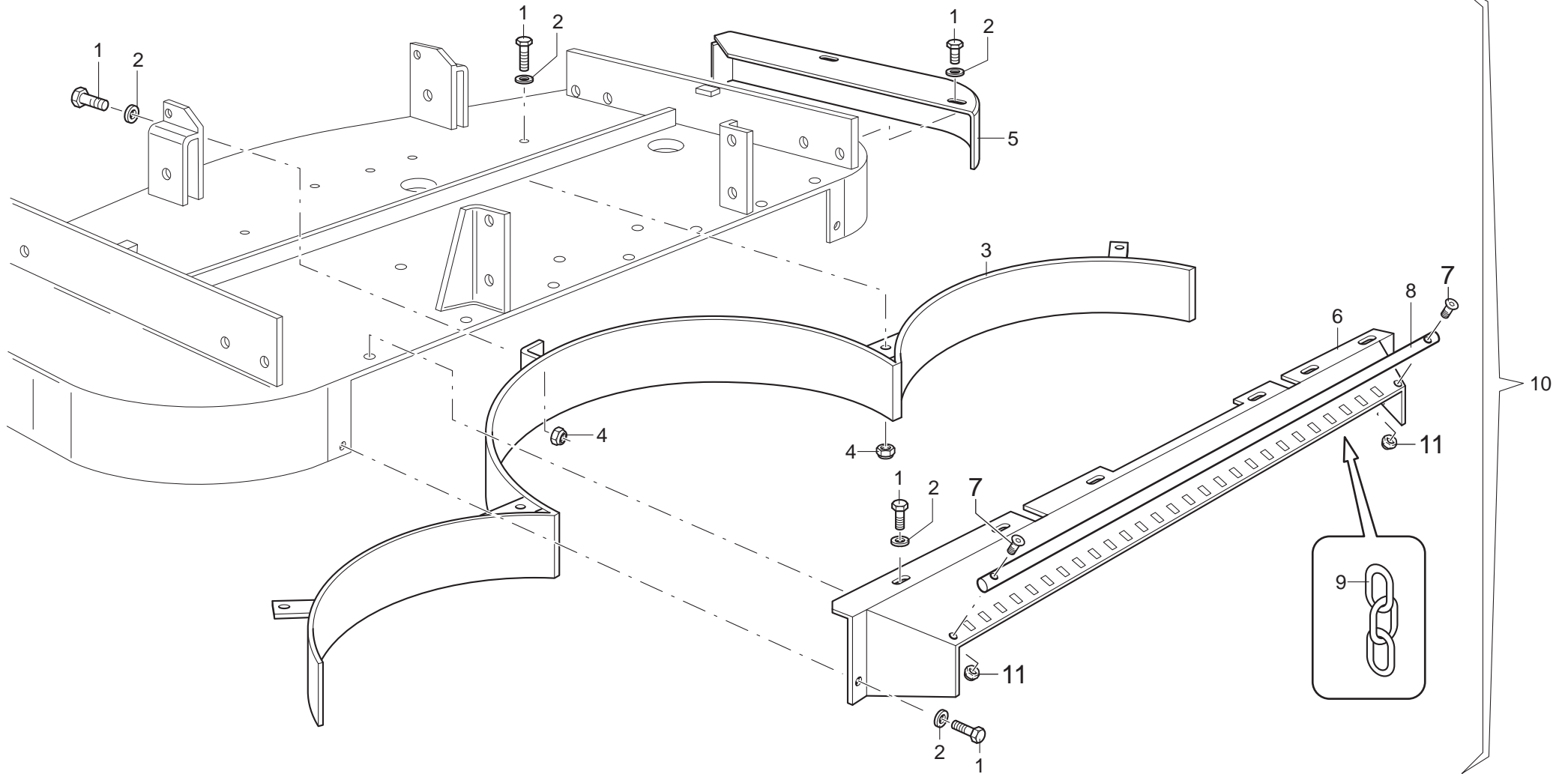

MURATORI MR ID

TAV. 6.0

POS.	N° CODICE	Q.	DESCRIZIONE	DESIGNATION	BENENNUNG	DESCRIPTION	DESIGNAZIONE	Da matr. De nr. serie Vom Seriennr. From serial nr.	Fino matr. Jusqu'au nr. serie Bis Seriennr. Up to serial nr.
1	60021600		VITE	VIS	SCHRAUBE	SCREW	TE 10 x 20 UNI 5739 8.8 ZNT		
2	61004900		RONDELLA	RONDELLE	SCHEIBE	WASHER	PIANA Ø 10 UNI 6592		
3	40233500	1	DEFLETTORE	DEFLECTEUR	LEITBLECH	DEFLECTOR	120		
3	40298000	1	DEFLETTORE	DEFLECTEUR	LEITBLECH	DEFLECTOR	135		
3	40233600	1	DEFLETTORE	DEFLECTEUR	LEITBLECH	DEFLECTOR	150		
3	40233700	1	DEFLETTORE	DEFLECTEUR	LEITBLECH	DEFLECTOR	180		
3	40298100	1	DEFLETTORE	DEFLECTEUR	LEITBLECH	DEFLECTOR	210		
4	62010400	3	DADO	ECROU	MUTTER	NUT	M 10 x 1.5 AUTOBLOCC.		
5	40233200	1	CHIUSURA	FERMETURE	VERSCHLUSS	GRIPPING	120		
5	40297800	1	CHIUSURA	FERMETURE	VERSCHLUSS	GRIPPING	135		
5	40233300	1	CHIUSURA	FERMETURE	VERSCHLUSS	GRIPPING	150		
5	40233400	1	CHIUSURA	FERMETURE	VERSCHLUSS	GRIPPING	180		
5	40297900	1	CHIUSURA	FERMETURE	VERSCHLUSS	GRIPPING	210		
6	39260401	1	CONVOGLIATORE	CONVOYEUR	LEITBLECH	CONVEYOR	120		
6	39305400	1	CONVOGLIATORE	CONVOYEUR	LEITBLECH	CONVEYOR	135		
6	39260501	1	CONVOGLIATORE	CONVOYEUR	LEITBLECH	CONVEYOR	150		
6	39260601	1	CONVOGLIATORE	CONVOYEUR	LEITBLECH	CONVEYOR	180		
6	39305500	1	CONVOGLIATORE	CONVOYEUR	LEITBLECH	CONVEYOR	210		
7	60015700	2	VITE	VIS	SCHRAUBE	SCREW	TE 6 25 UNI 5739		
8	31078300	1	SPINA	GOUPILLE	STIFT	PIN	120		
8	31095000	1	SPINA	GOUPILLE	STIFT	PIN	135		
8	31078400	1	SPINA	GOUPILLE	STIFT	PIN	150		
8	31078500	1	SPINA	GOUPILLE	STIFT	PIN	180		
8	31095100	1	SPINA	GOUPILLE	STIFT	PIN	210		
9	68086000		CATENA	CHAINE	KETTE	CHAIN			
10	45113000		KIT SCARICO POSTERIORE	KIT DECHARG. ARRIERE	SATZ HECKAUSWURF	KIT REAR DISCHARGE	120		

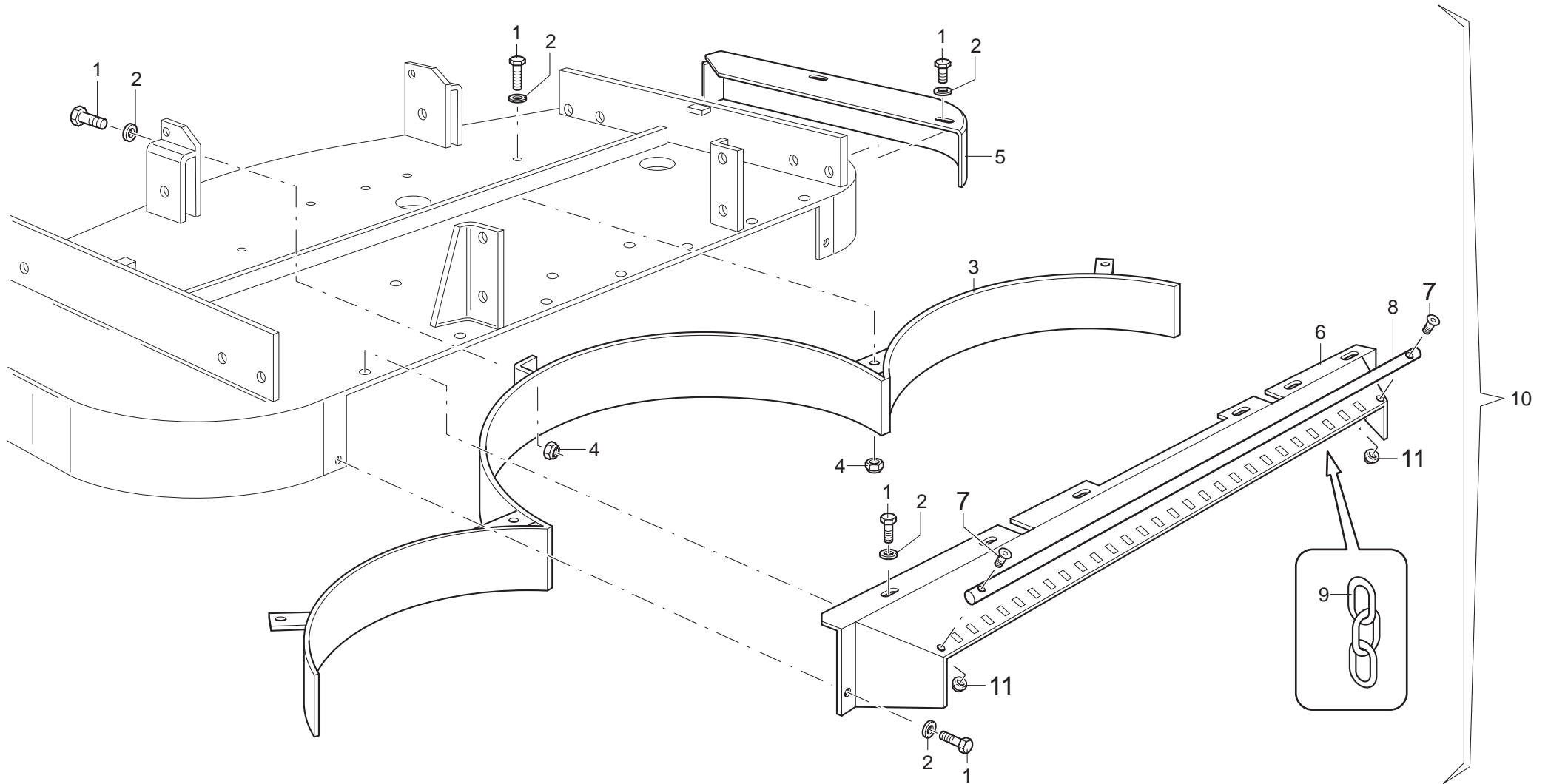

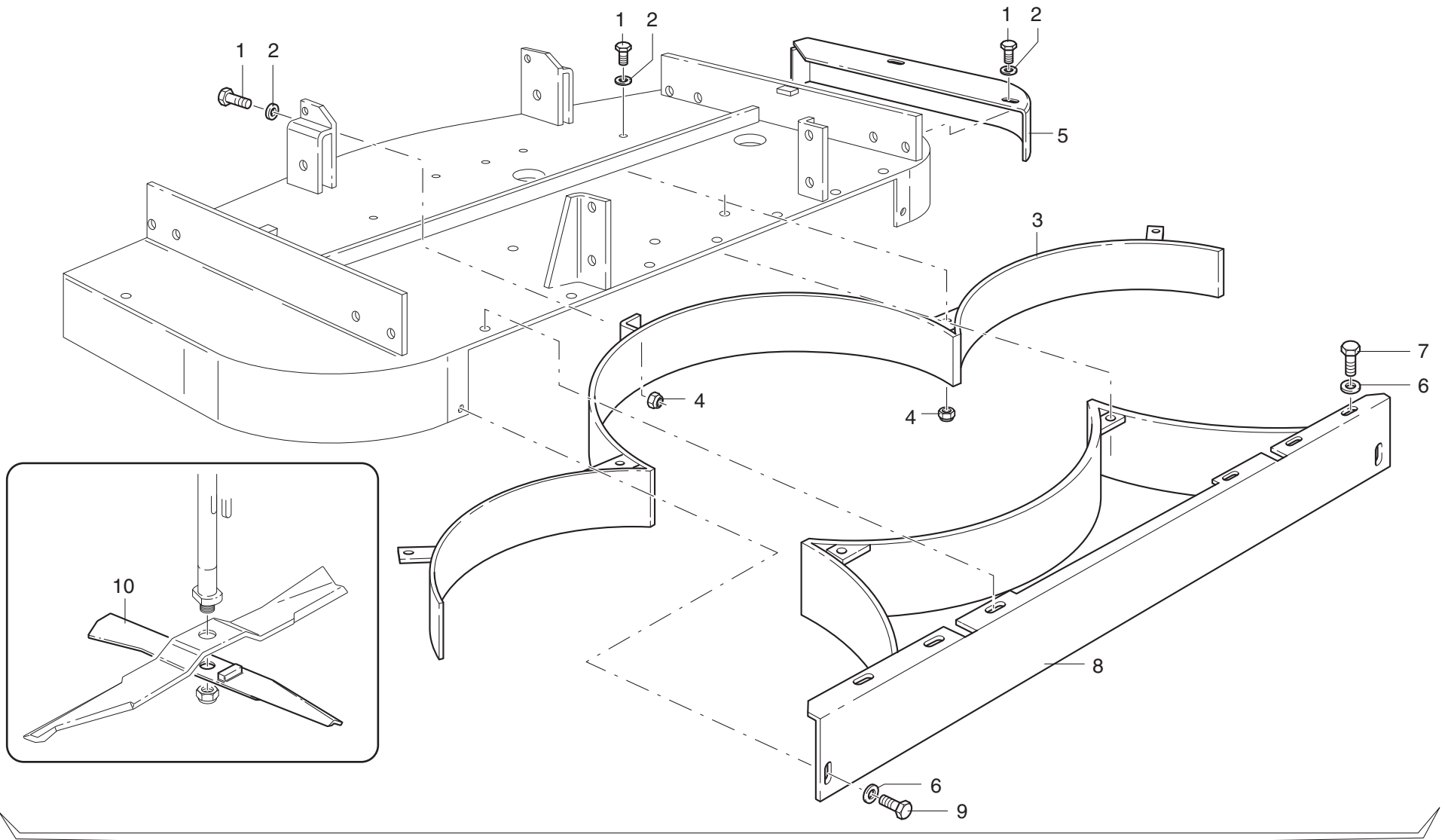

MURATORI MR ID

TAV. 7.0

POS.	N° CODICE	Q.	DESCRIZIONE	DESIGNATION	BENENNUNG	DESCRIPTION	DESIGNAZIONE	Da matr. De nr. serie Vom Seriennr. From serial nr.	Fino matr. Jusqu'au nr. serie Bis Seriennr. Up to serial nr.
1	60021600		VITE	VIS	SCHRAUBE	SCREW	TE 10 x 20 UNI 5739 8.8 ZNT		
2	61004900		RONDELLA	RONDELLE	SCHEIBE	WASHER	PIANA Ø 10 UNI 6592		
3	40233500	1	DEFLETTORE	DEFLECTEUR	LEITBLECH	DEFLECTOR	120		
3	40298000	1	DEFLETTORE	DEFLECTEUR	LEITBLECH	DEFLECTOR	135		
3	40233600	1	DEFLETTORE	DEFLECTEUR	LEITBLECH	DEFLECTOR	150		
3	40233700	1	DEFLETTORE	DEFLECTEUR	LEITBLECH	DEFLECTOR	180		
3	40298100	1	DEFLETTORE	DEFLECTEUR	LEITBLECH	DEFLECTOR	210		
4	62010400	3	DADO	ECROU	MUTTER	NUT	M 10 x 1.5 AUTOBLOCC.		
5	40233200	1	CHIUSURA	FERMETURE	VERSCHLUSS	GRIPPING	120		
5	40297800	1	CHIUSURA	FERMETURE	VERSCHLUSS	GRIPPING	135		
5	40233300	1	CHIUSURA	FERMETURE	VERSCHLUSS	GRIPPING	150		
5	40233400	1	CHIUSURA	FERMETURE	VERSCHLUSS	GRIPPING	180		
5	40297900	1	CHIUSURA	FERMETURE	VERSCHLUSS	GRIPPING	210		
6	61004900	8	RONDELLA	RONDELLE	SCHEIBE	WASHER	PIANA Ø 10 UNI 6592		
7	60021600	6	VITE	VIS	SCHRAUBE	SCREW	TE 10 x 20 UNI 5739 8.8 ZNT		
8	40232900	1	CHIUSURA	FERMETURE	VERSCHLUSS	GRIPPING	120		
8	40297600	1	CHIUSURA	FERMETURE	VERSCHLUSS	GRIPPING	135		
8	40233000	1	CHIUSURA	FERMETURE	VERSCHLUSS	GRIPPING	150		
8	40233100	1	CHIUSURA	FERMETURE	VERSCHLUSS	GRIPPING	180		
8	40297700	1	CHIUSURA	FERMETURE	VERSCHLUSS	GRIPPING	210		
9	60038700	2	VITE	VIS	SCHRAUBE	SCREW	TBCE 10 x 25 UNI 7380		
10	12.0182.00	3	LAMA "MULCHING"	LAME DE COUPE "MULCHING"	"MULCHING" SCHNEIDKANTE	"MULCHING" BLADE	120		
10	12.0214.00	3	LAMA "MULCHING"	LAME DE COUPE "MULCHING"	"MULCHING" SCHNEIDKANTE	"MULCHING" BLADE	135		
10	12.0183.00	3	LAMA "MULCHING"	LAME DE COUPE "MULCHING"	"MULCHING" SCHNEIDKANTE	"MULCHING" BLADE	150		
10	12.0184.00	3	LAMA "MULCHING"	LAME DE COUPE "MULCHING"	"MULCHING" SCHNEIDKANTE	"MULCHING" BLADE	180		
10	12.0215.00	3	LAMA "MULCHING"	LAME DE COUPE "MULCHING"	"MULCHING" SCHNEIDKANTE	"MULCHING" BLADE	210		

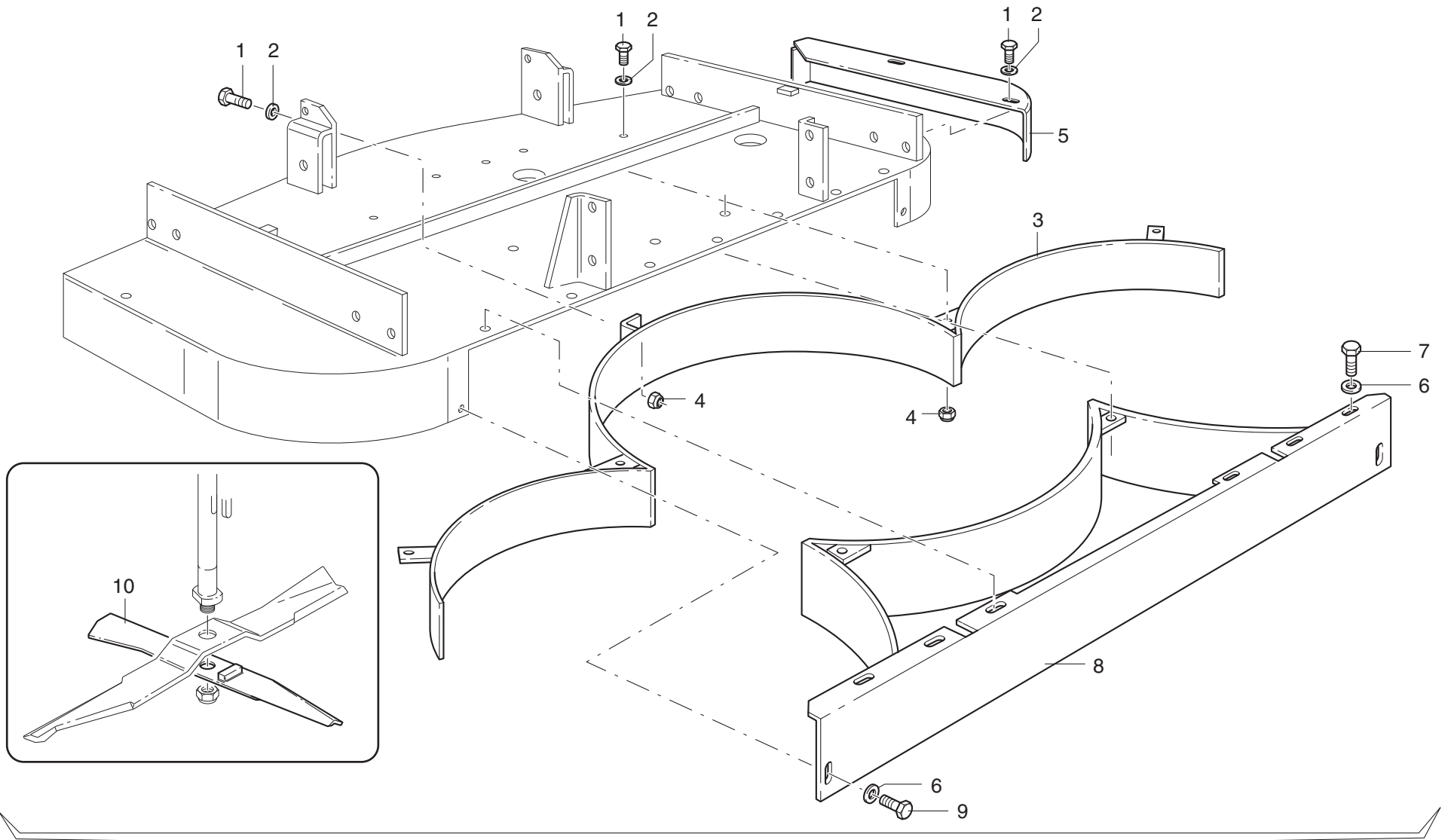

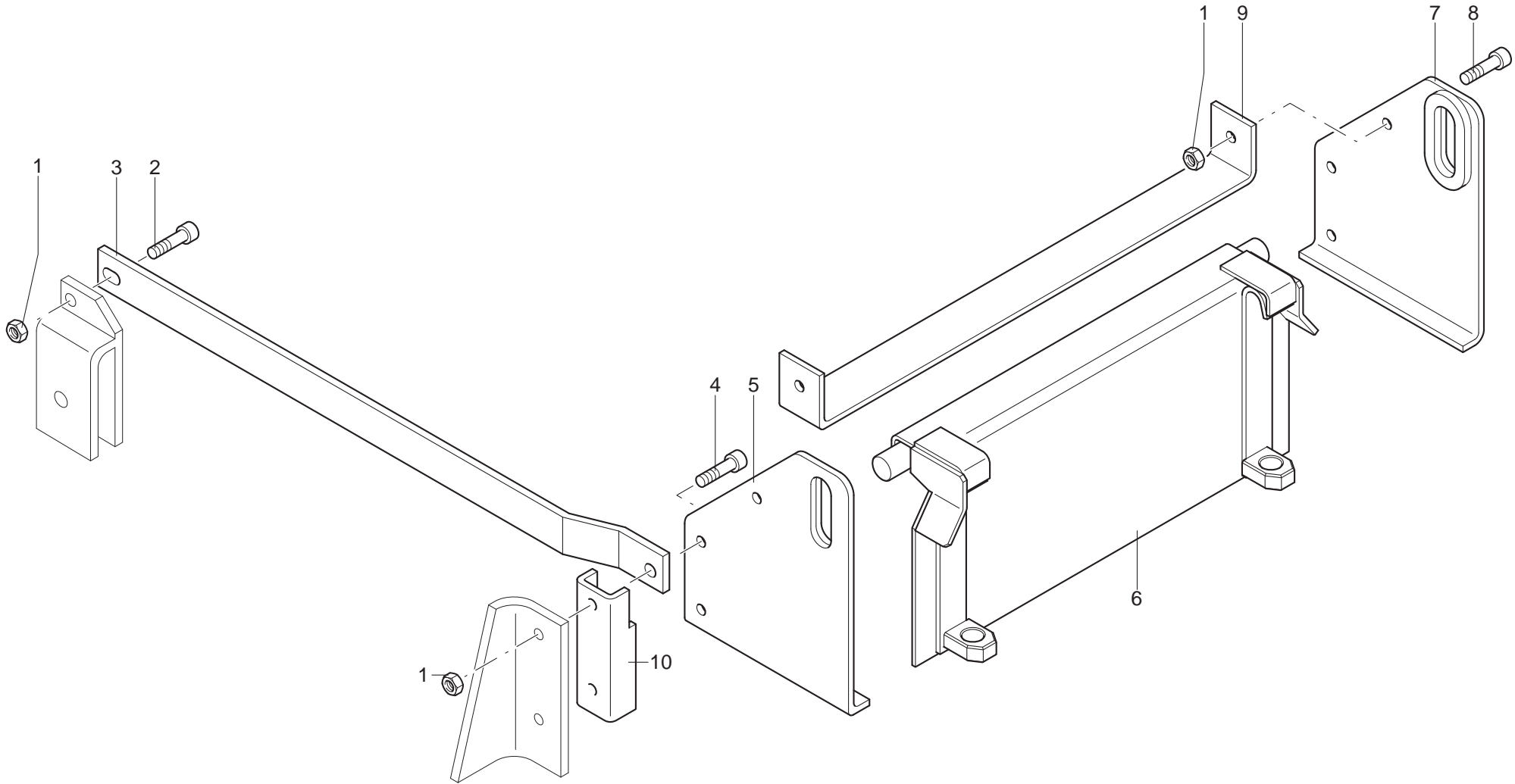

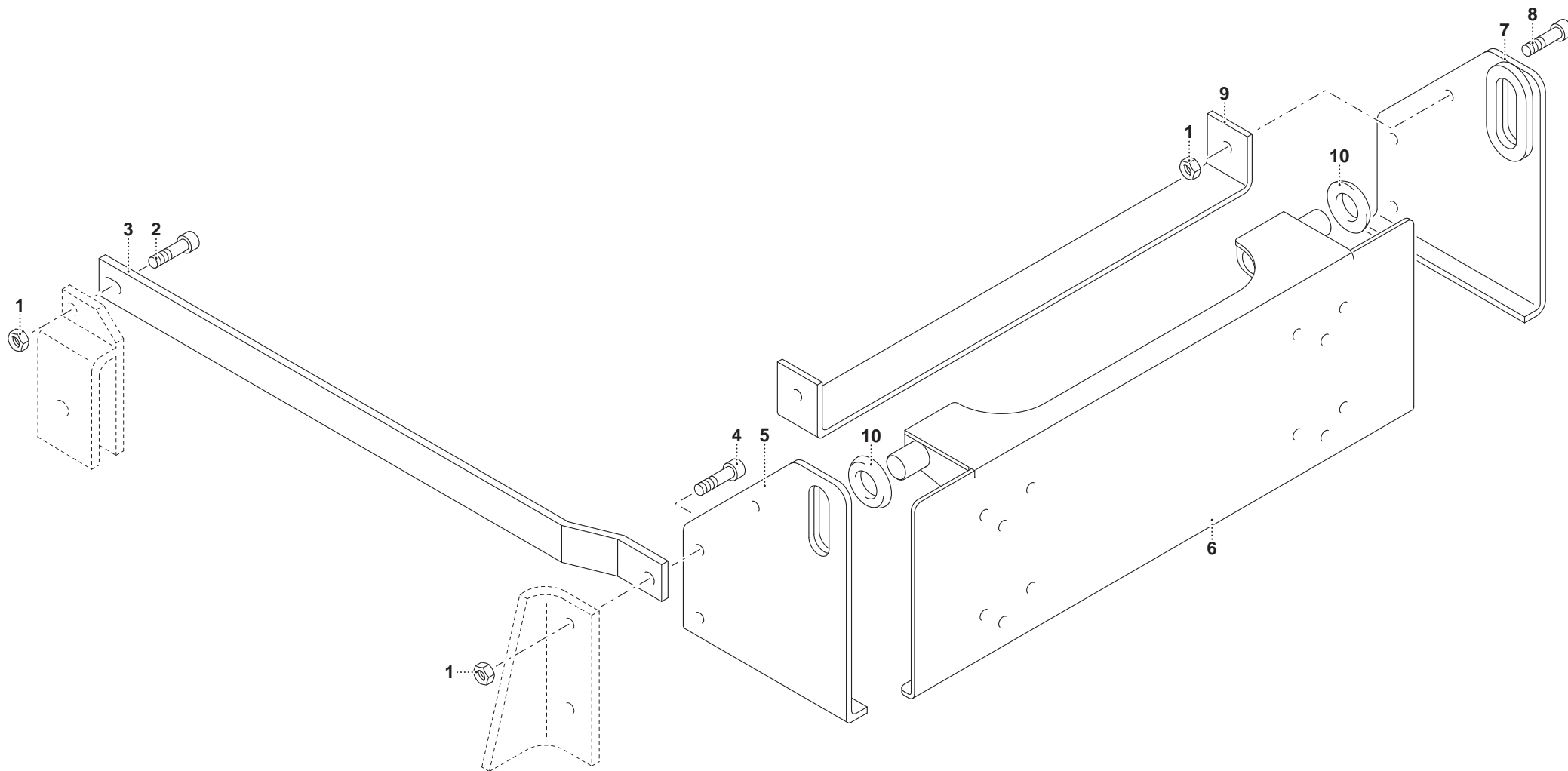

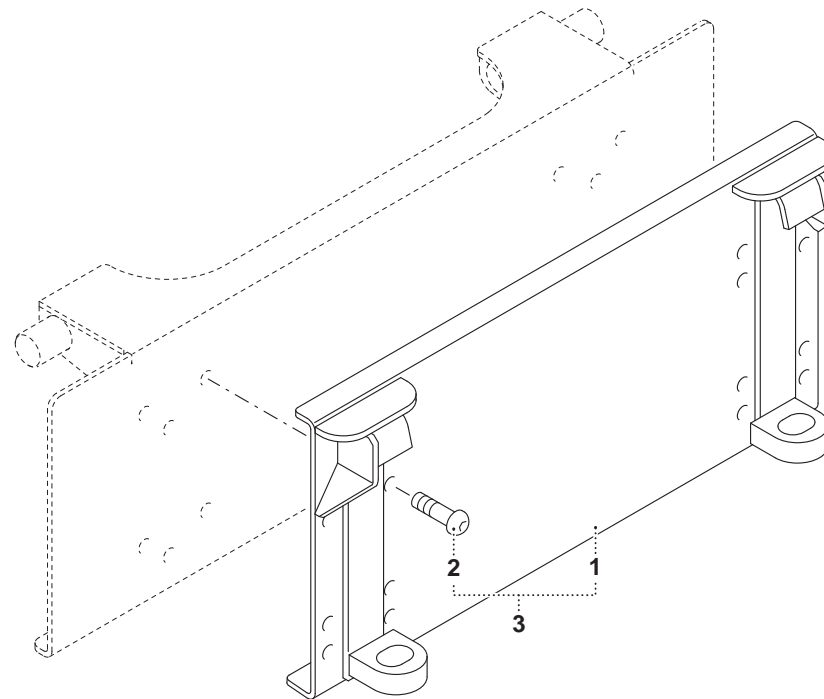

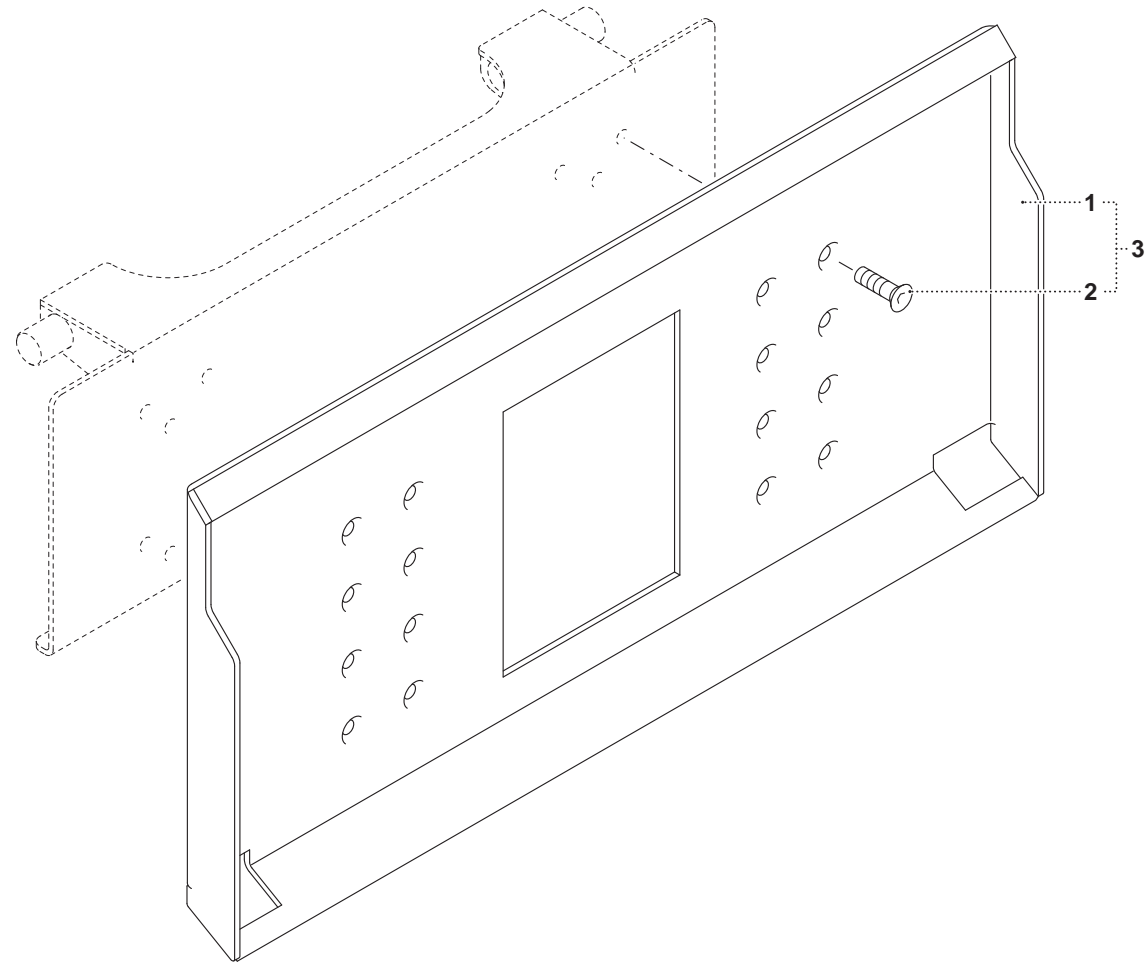

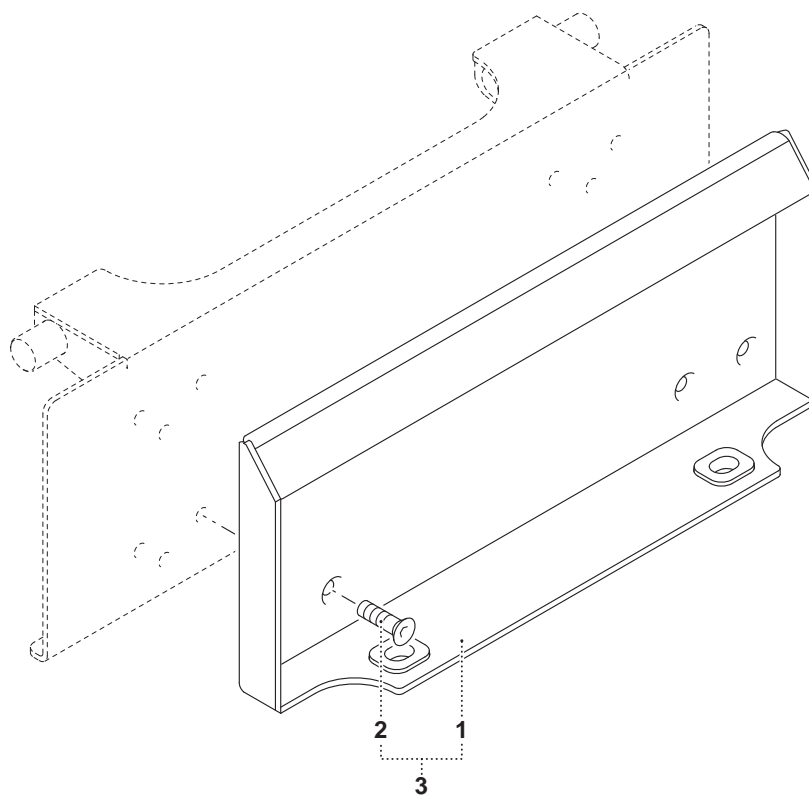

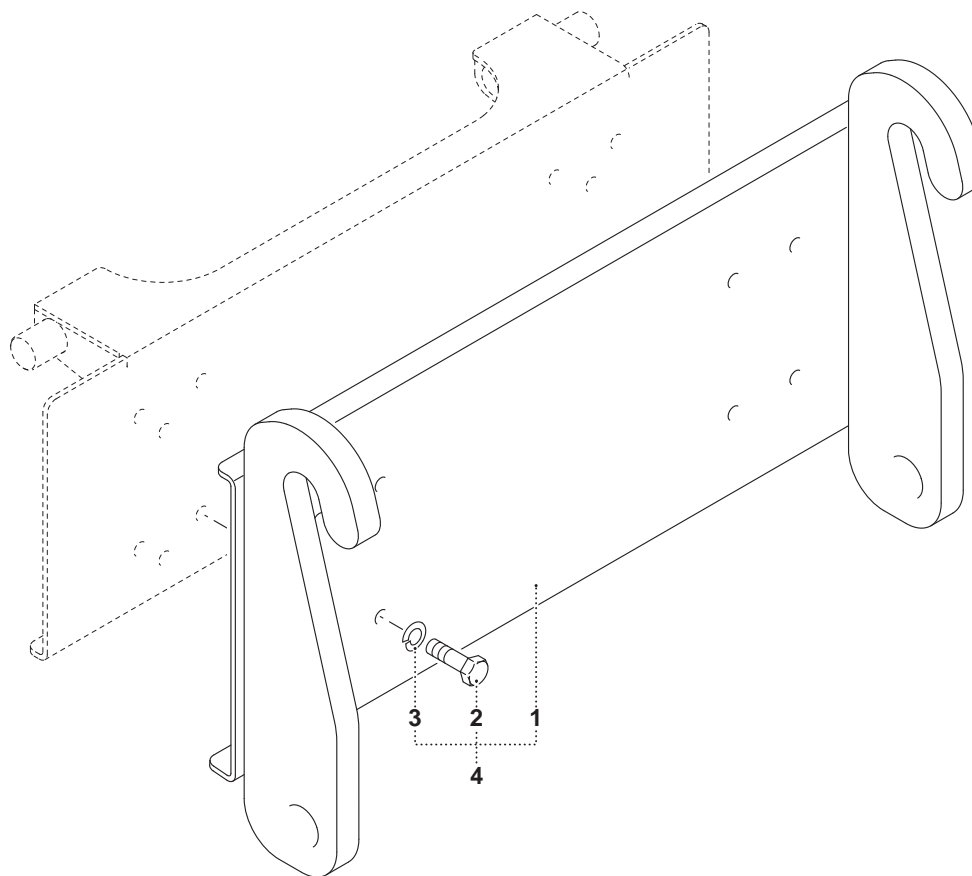

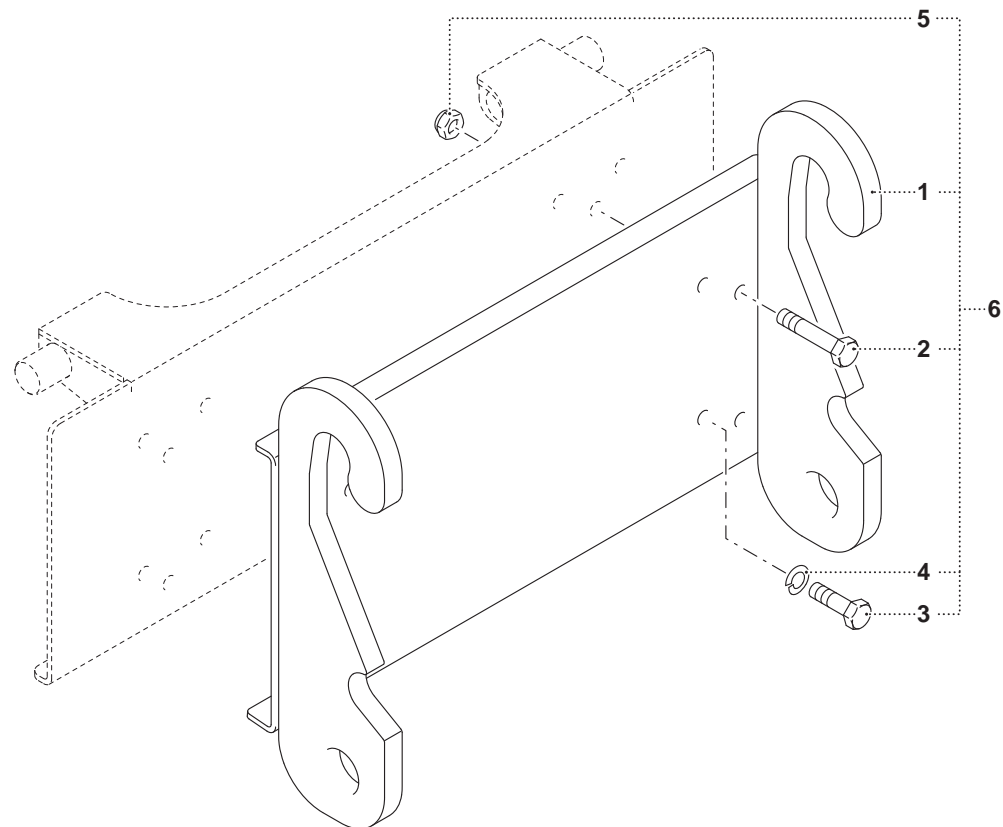

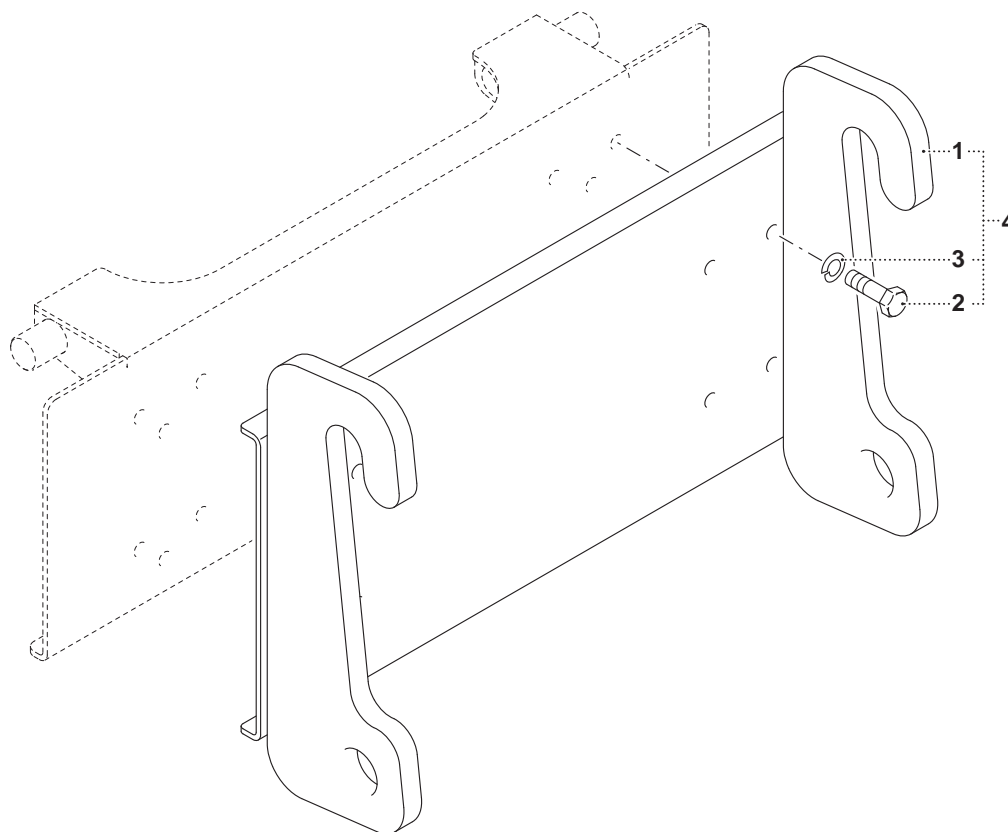

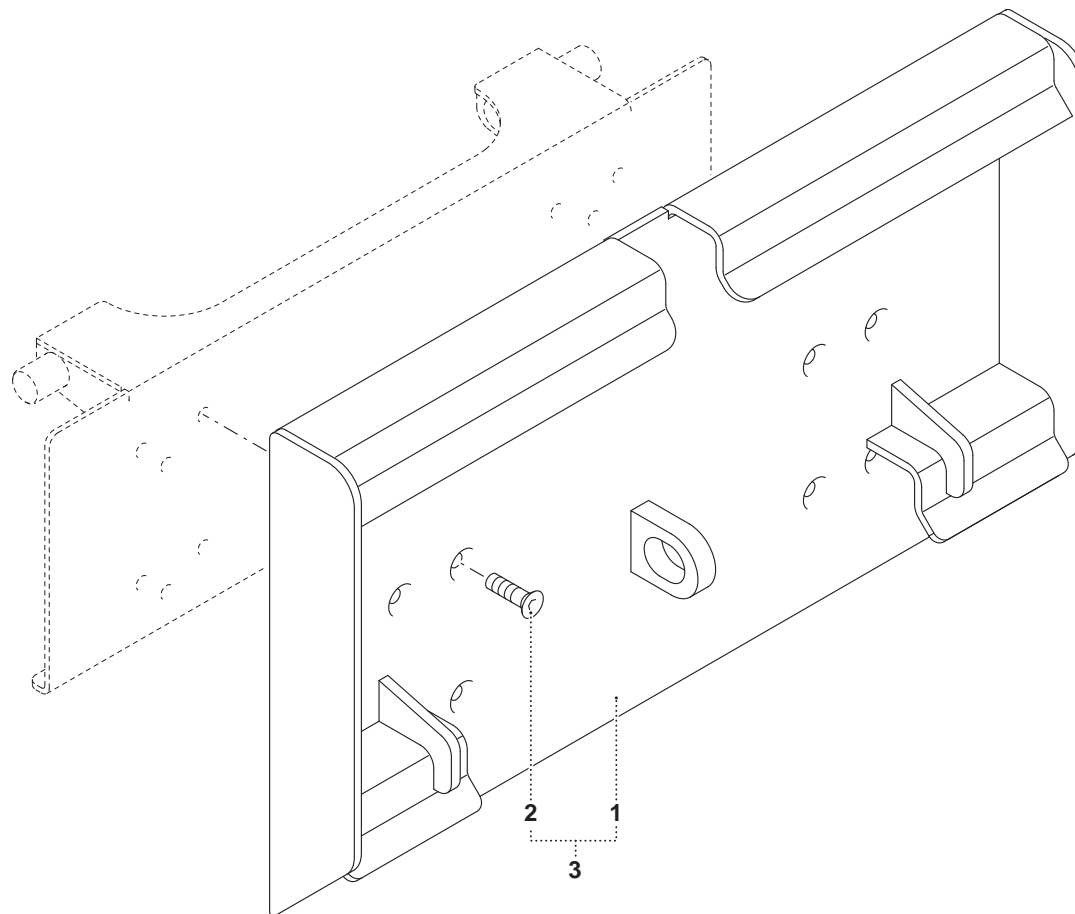

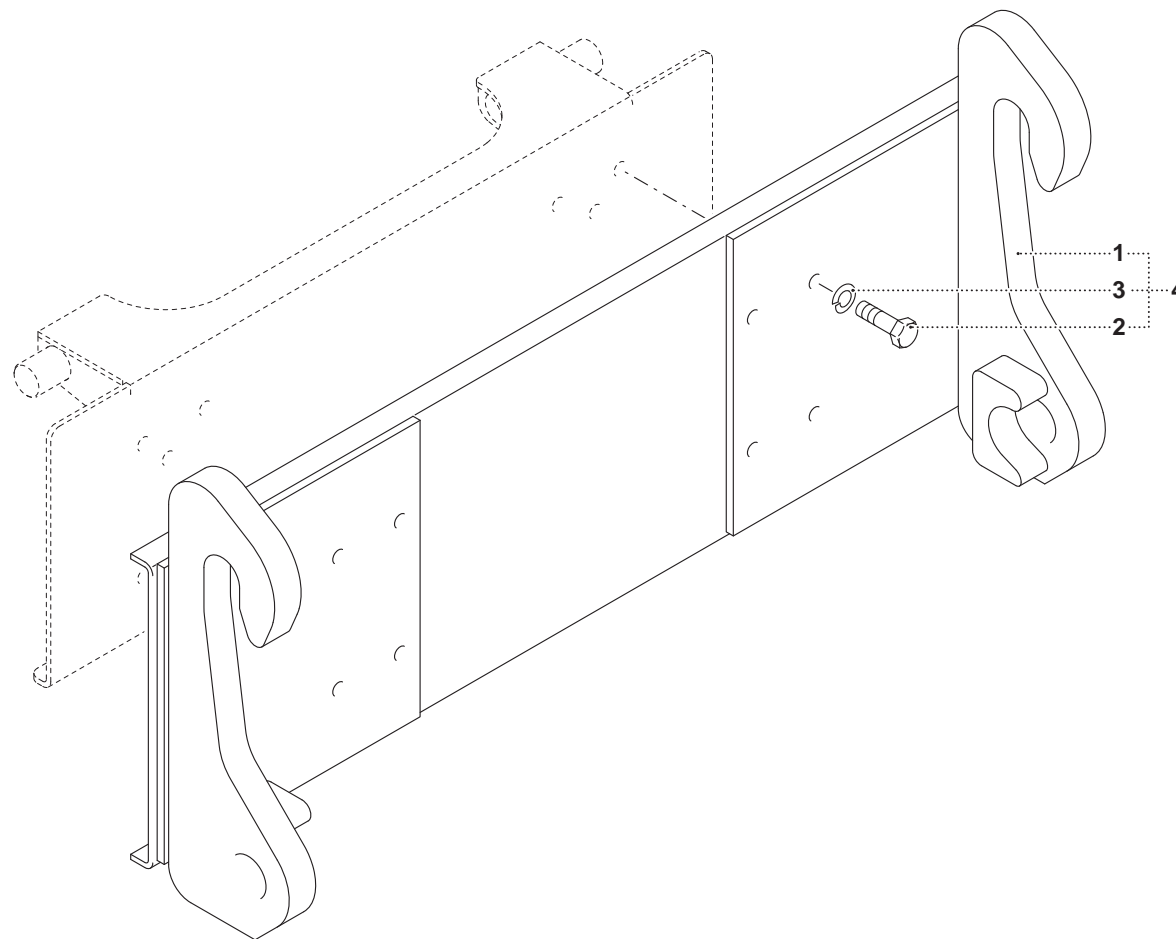

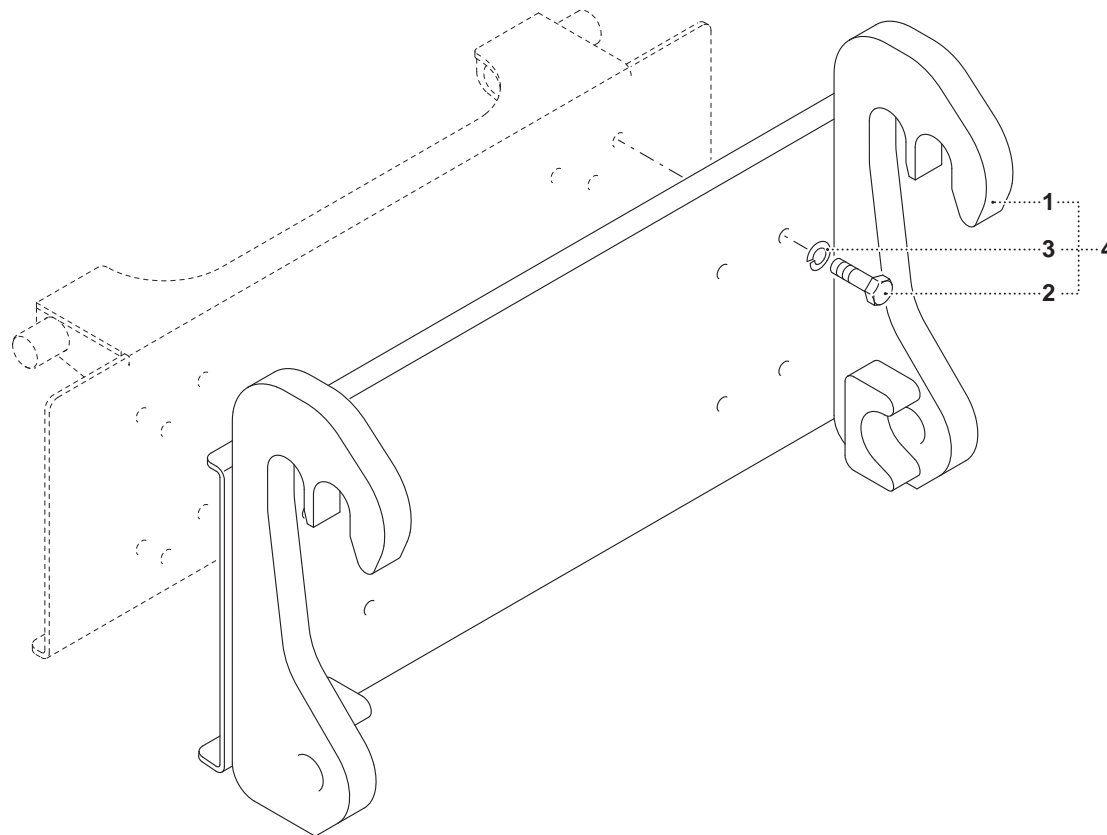



MURATORI S.p.A.

Via Pavarello, 21 - 41051 Castelnuovo Rangone (MO) Italy - Tel. 059.5330611 Fax 059.537259

www.muratoriequip.it *info@muratoriequip.it*

Capitale sociale Euro 480.000 interamente versato

Registro Imprese di Modena

Codice fiscale e numero d'iscrizione: 00708860366