



MURATORI

**TIPO-TYPE-TYP
MT 11**

CATALOGO RICAMBI
Catalogue Pièces Detachées
Ersatzteilkatalog
Spare Parts Catalogue
Catálogo Recambios

EDIZIONE 06/2019

Per ordinare parti di ricambio specificare:

- tipo e matricola della macchina (apposti sulla macchina o sui documenti di acquisto);
- numero del riferimento del pezzo nel disegno (Pos.), numero della tavola (Tav.) e numero di codice

N.B.: le indicazioni destro o sinistro vengono date guardando la macchina da dietro.

Pour les commandes de pièces de rechange veuillez spécifier:

- *type et numéro de série de la machine (indiqués sur la machine et sur le bon d'achat);*
- *numéro de référence du pièce sur le plan (Pos.), numéro du plan (Tav.) et numéro de code (codice)*

N.B.: *les indications droite ou gauche sont données en regardant la machine par derrière.*

Zum Bestellen von Ersatzteilen folgendes angeben:

- Typ und Serien-Nr. der Maschine (zu finden auf der Maschine oder der Einkaufspapieren);
- Bezug-Nr. des Ersatzteils auf der Zeichnung (Pos.), Zeichnungsnummer (Tav.) und Kodenummer (codice)

N.B.: die Angaben rechts und links verstehen sich so, dass man hinter der Maschine steht.

When ordering spare parts specify:

- *machine type and serial number (found on the machine or on the purchasing documents);*
- *reference number of the part on the relative drawing (Pos.), number of the drawing (Tav.) and part number (codice)*

N.B.: *right-hand or left-hand indications are made by viewing the machine from the rear.*

TAV. 1.0

GRUPPO TELAIO
ENSEMBLE CHASSIS
SATZ FÜR RAHMEN
KIT FOR FRAME

TAV. 2.0

GRUPPO TRASMISSIONE ROTORE
ENSEMBLE TRANSMISSION ROTORS
SATZ FÜR DEN ROTARONTRIEB
KIT FOR THE ROTOR TRANSMISSION

TAV. 3.0

GRUPPO RULLO POSTERIORE
ENSEMBLE ROULEAU ARRIERE
SATZ HINTERE WALZE
KIT REAR ROLLER

TAV. 4.0

GRUPPO MOLTIPLICATORE - 540 RPM
ENSEMBLE MULTIPLICATEUR - 540 RPM
SATZ FÜR GETRIEBE - 540 RPM
KIT FOR GEAR BOX - 540 RPM

TAV. 5.0

ATTACCO FRONTALE
ATTELAGE FRONTAL
FRONTANBAU
FRONT LINKAGE

TAV.6.0

ATTACCO SCORREVOLE (105-135)
ATTELAGE DEPLAÇABLE (105-135)
VERSCHIEBBARER ANSCHLUSS (105-135)
SIDE SHIFTING HITCH (105-135)

TAV. 7.0

ATTACCO FRONTALE SCORREVOLE (105-135)
ATTELAGE FRONTAL DEPLAÇABLE (105-135)
VERSCHIEBBARER FRONTANSCHLUSS (105-135)
SLIDING FRONT HITCH (105-135)

TAV. 8.0

ATTACCO FRONTALE RAPIDO - RUOTE
ATTELAGE FRONTAL RAPIDE - ROUES
FRONTKUPPELDREIECK - RADER
QUICK FRONT LINKAGE - WHEELS

TAV. 9.0

ACCESSORI A COMPLETAMENTO
OPTIONS D'ACHEVEMENT
ZUBEHÖRE ZUR ERGANZUNG DER MASCHINE
CHOICE OF EQUIPMENT COMPLETING MACHINE

TAV. 10.0

ALBERO CARDANICO COMPLETO - AB107SF
ARBRE A JOINTS DE CARDAN - AB107SF
KARDANWELLE - AB107SF
PTO SHAFT - AB107SF

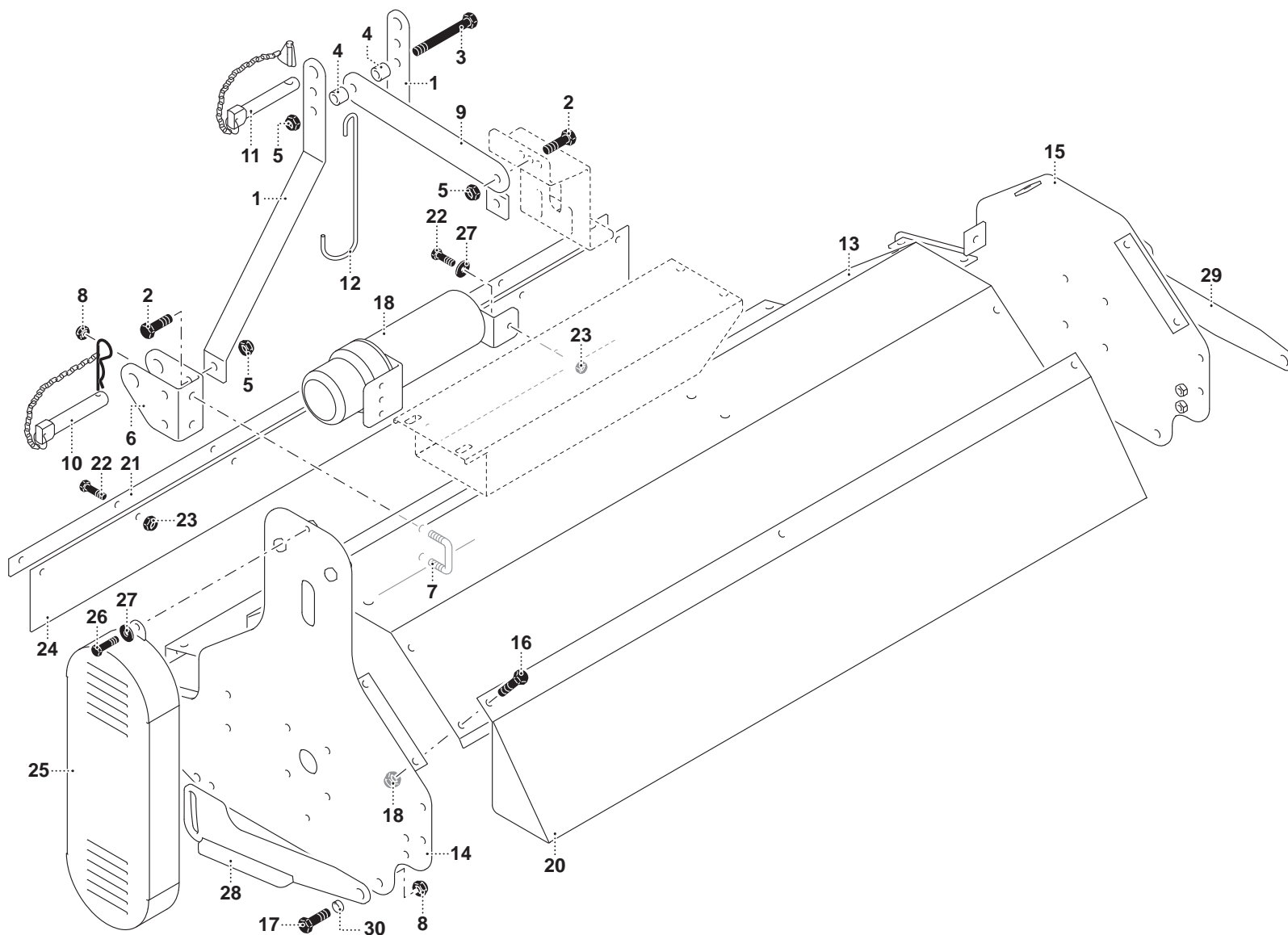

MURATORI MT11

TAV. 1.0

POS.	N° CODICE	Q.	DESCRIZIONE	DESIGNATION	BENENNUNG	DESCRIPTION	DESIGNAZIONE	Da matr. De nr. serie Vom Seriennr. From serial nr.	Fino matr. Jusqu'au nr. serie Bis Seriennr. Up to serial nr.
1	30211200	2	TIRANTE	TIRANT	STANGE	TIEROD			
2	60020400	3	VITE	VIS	SCHRAUBE	SCREW	TE 12x25 UNI 5739 ZNT		
3	60021500	1	VITE	VIS	SCHRAUBE	SCREW	TE 12x80 UNI 5737 ZNT		
4	32182700	2	DISTANZIALE	ENTRETOISE	DISTANZSTÜCK	SPACER			
5	62010600	4	DADO	ECROU	MUTTER	NUT	M12 AUTOBLOCC.		
6	30031101	2	STAFFA	BRIDE	BÜGEL	BRACKET			
7	38027900	2	CAVALLOTTO	ARRETOIR	KLEMMSTÜCK	UBOLT	M10		
8	62010400	21	DADO	ECROU	MUTTER	NUT	M10 AUTOBLOCC.		
9	30210700	1	TIRANTE	TIRANT	STANGE	TIEROD			
10	68062300	2	PERNO	PIVOT	BOLZEN	PIN			
11	68062000	1	PERNO	PIVOT	BOLZEN	PIN			
12	38024500	1	GANCIO	CROCHET	HAKEN	HOOK			
13	39366300	1	TELAIO	CHASSIS	RAHMEN	FRAME	85		
13	39366400	1	TELAIO	CHASSIS	RAHMEN	FRAME	105		
13	39366500	1	TELAIO	CHASSIS	RAHMEN	FRAME	125		
13	39366600	1	TELAIO	CHASSIS	RAHMEN	FRAME	135		
14	40337200	1	FIANCO SX	FLANC (G)	SEITENWAND (L)	SIDE FRAME (LH)			
15	40337300	1	FIANCO DX	FLANC (D)	SEITENWAND (R)	SIDE FRAME (RH)			
16	60021600	11	VITE	VIS	SCHRAUBE	SCREW	TE 10x20 UNI 5739 ZNT		
17	60021300	6	VITE	VIS	SCHRAUBE	SCREW	TE 10x30 UNI 5739 ZNT		
18	68117400	1	PORTADOCUMENTI	PORTE-DOCUMENTS	AKTENTASCHEN	DOCUMENT HOLDER			
19	30209500	1	BARRA	BARRE	STANGE	BAR	85		
19	30209600	1	BARRA	BARRE	STANGE	BAR	105		
19	30209800	1	BARRA	BARRE	STANGE	BAR	125		
19	30218100	1	BARRA	BARRE	STANGE	BAR	135		
20	39321300	1	LAMIERA	TOLE	BLECH	SHEET	85		

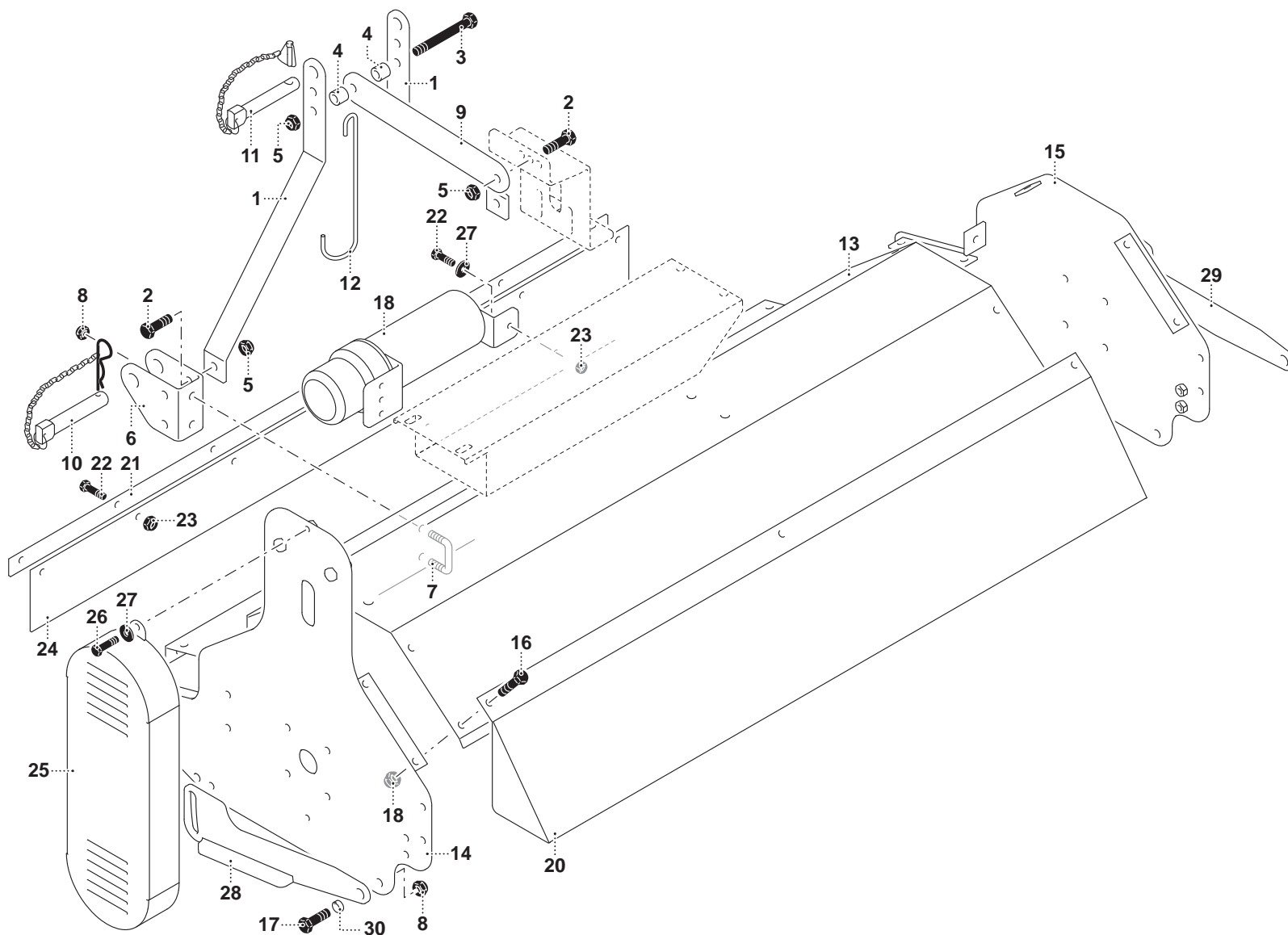

MURATORI MT11

TAV. 1.0

POS.	N° CODICE	Q.	DESCRIZIONE	DESIGNATION	BENENNUNG	DESCRIPTION	DESIGNAZIONE	Da matr. De nr. serie Vom Seriennr. From serial nr.	Fino matr. Jusqu'au nr. serie Bis Seriennr. Up to serial nr.
20	39321400	1	LAMIERA	TOLE	BLECH	SHEET	105		
20	39321500	1	LAMIERA	TOLE	BLECH	SHEET	125		
20	39368300	1	LAMIERA	TOLE	BLECH	SHEET	135		
21	30196400	1	PIATTO	PLAQUE	PLATTE	DISC	85		
21	30125500	1	PIATTO	PLAQUE	PLATTE	DISC	105		
21	30204400	1	PIATTO	PLAQUE	PLATTE	DISC	125		
21	30218200	1	PIATTO	PLAQUE	PLATTE	DISC	135		
22	60026900	7	VITE	VIS	SCHRAUBE	SCREW	TE 8x25 UNI 5739 ZNT		
23	62010200	7	DADO	ECROU	MUTTER	NUT	M8 AUTOBLOCC.		
24	68093100	1	BANDELLA	BANDE	BAND	STRAP	85		
24	68093105	1	BANDELLA	BANDE	BAND	STRAP	105		
24	68112000	1	BANDELLA	BANDE	BAND	STRAP	125		
24	68136500	1	BANDELLA	BANDE	BAND	STRAP	135		
25	40337700	1	CARTER	CARTER	KETTENKASTEN	CASING			
26	60022800	2	VITE	VIS	SCHRAUBE	SCREW	TE 8x20 UNI 5739 ZNT		
27	61006200	4	RONDELLA	RONDELLE	SCHEIBE	WASHER	PIANA Ø9 UNI 6592		
28	39357900	1	BANDELLA SX	BANDE (G)	BAND (L)	STRAP(LH)			
29	39357905	1	BANDELLA DX	BANDE (D)	BAND (R)	STRAP(RH)			
30	31079300	4	BOCCOLA	DOUILLE	BUCHSE	BUSHING			

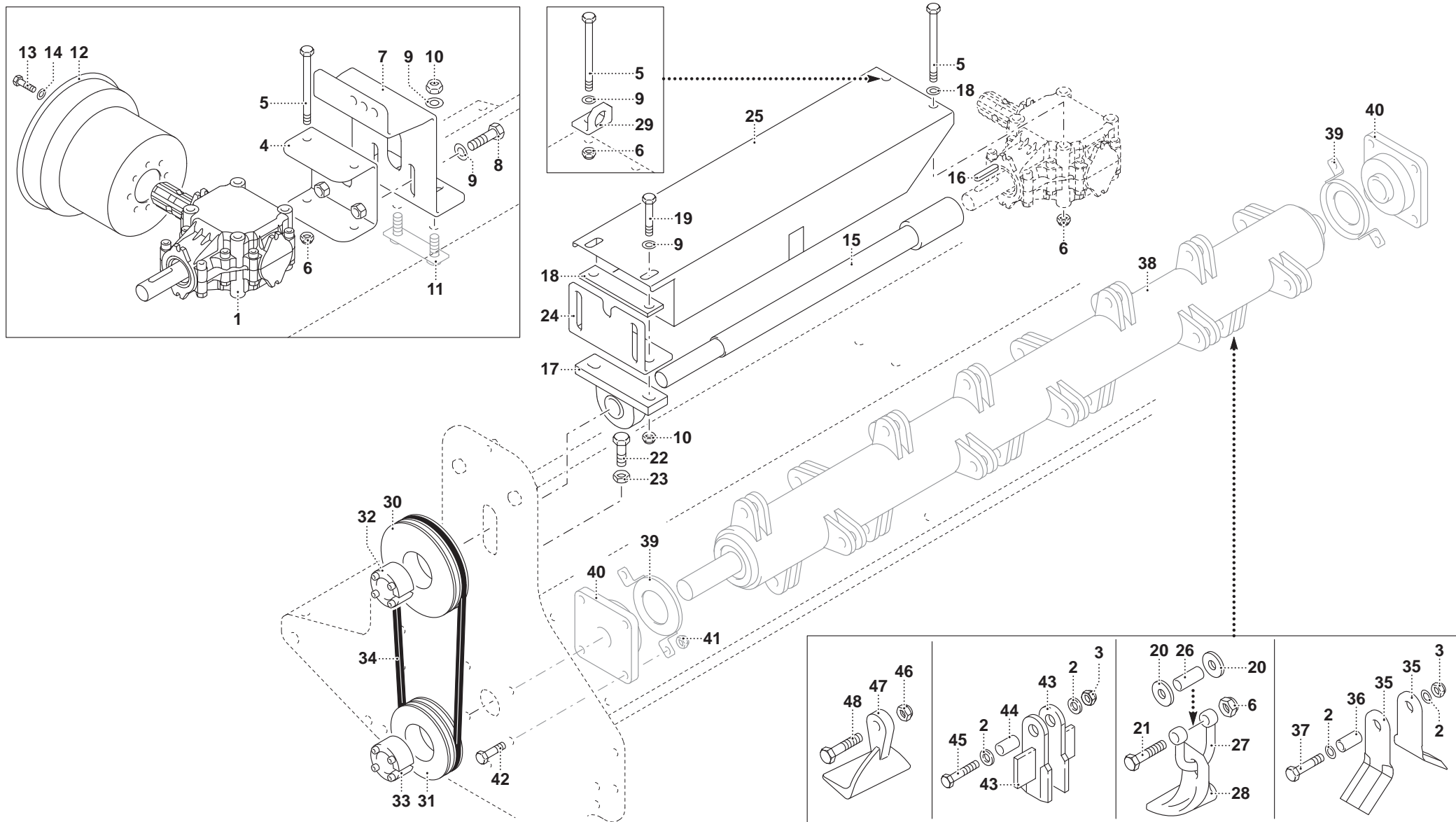

MURATORI MT11

TAV. 2.0

POS.	N° CODICE	Q.	DESCRIZIONE	DESIGNATION	BENENNUNG	DESCRIPTION	DESIGNAZIONE	Da matr. De nr. serie Vom Seriennr. From serial nr.	Fino matr. Jusqu'au nr. serie Bis Seriennr. Up to serial nr.
1	46036600	1	MOLTIPLICATORE ORARIO	BOITIER (ROT. STANDARD)	RECHTSDR. GETRIEBE	CLOCKWISE GEAR BOX			
1	46036700	1	MOLTIPLICATORE ANTIORARIO	BOITIER (ROT. INVERSE)	LINKSDR. GETRIEBE	COUNTERCL. GEAR BOX			
2	61006200		RONDELLA	RONDELLE	SCHEIBE	WASHER	PIANA Ø9		
3	62010200		DADO	ECROU	MUTTER	NUT	M8 AUTOBLOCC.		
4	40336700	1	SUPPORTO	SUPPORT	HALTERUNG	SUPPORT			
5	60020700	4	VITE	VIS	SCHRAUBE	SCREW	TE 10x120 UNI 5737 ZNT		
6	62010400	4	DADO	ECROU	MUTTER	NUT	M10 AUTOBLOCC.		
7	39366700	1	SUPPORTO	SUPPORT	HALTERUNG	SUPPORT			
8	60020400	2	VITE	VIS	SCHRAUBE	SCREW	TE 12x25 UNI 5737 ZNT		
9	61005000	11	RONDELLA	RONDELLE	SCHEIBE	WASHER	PIANA Ø12 UNI 6582		
10	62010600	6	DADO	ECROU	MUTTER	NUT	M12 AUTOBLOCC.		
11	40231800	1	PIATTO	PLAQUE	PLATTE	DISC			
12	68074300	1	PROTEZIONE	PROTECTION	SCHUTZ	GUARD			
13	60024800	1	VITE	VIS	SCHRAUBE	SCREW	TE 6x16 UNI 5739 ZNT		
14	61006000	2	RONDELLA	RONDELLE	SCHEIBE	WASHER	PIANA Ø6 FASCIA LARGA		
15	40254900	1	PROLUNGA	RALLONGE	VERLÄNGERUNGSROHR	EXTENSION	85		
15	40228501	1	PROLUNGA	RALLONGE	VERLÄNGERUNGSROHR	EXTENSION	105		
15	40296600	1	PROLUNGA	RALLONGE	VERLÄNGERUNGSROHR	EXTENSION	125 / 135		
16	65002900	1	CHIAVETTA	CLAVETTE	SCHLÜSSEL	KEY	8 x 7 x 35		
17	67012600	1	SUPPORTO	SUPPORT	HALTERUNG	SUPPORT	UCP 205		
18	30217600	1	SPESSORE	EPAISSEUR	DISTANZRING	SPACER			
19	60035500	2	VITE	VIS	SCHRAUBE	SCREW	TE 12x50 UNI 5739 ZNT		
20	39306200		RONDELLA	RONDELLE	SCHEIBE	WASHER	PIANA 14 x 37 x 4		
21	60030200		VITE	VIS	SCHRAUBE	SCREW	TE 10x80 UNI 5739 ZNT		
22	60042600	1	VITE	VIS	SCHRAUBE	SCREW	TE 10x50 ZNT		
23	62001100	1	DADO	ECROU	MUTTER	NUT	M12 BASSO		

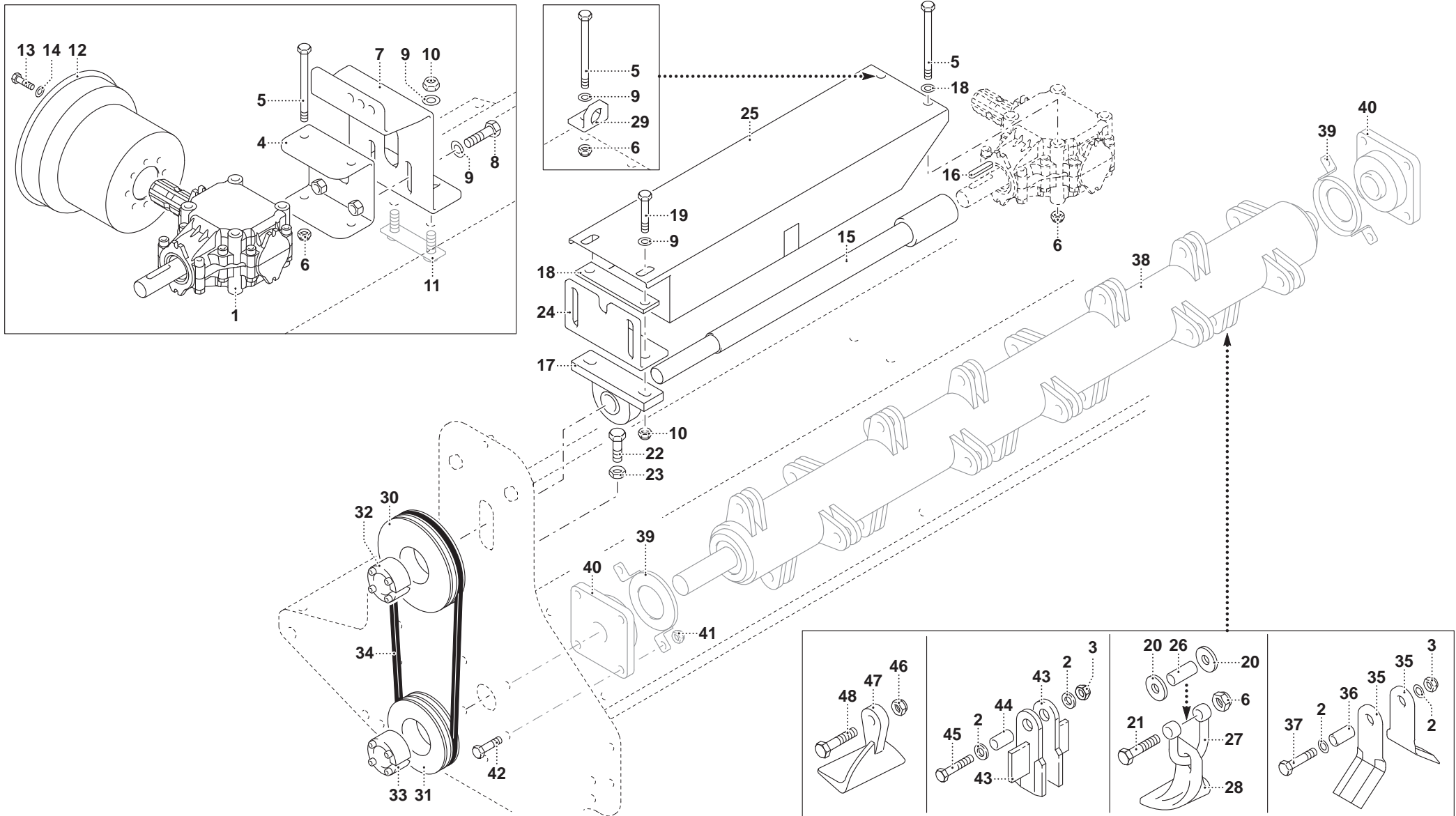

MURATORI MT11

TAV. 2.0

POS.	N° CODICE	Q.	DESCRIZIONE	DESIGNATION	BENENNUNG	DESCRIPTION	DESIGNAZIONE	Da matr. De nr. serie Vom Seriennr. From serial nr.	Fino matr. Jusqu'au nr. serie Bis Seriennr. Up to serial nr.
24	39253600	1	REGOLAZIONE	REGULATEUR	MECHANISCHER	REGLER GOVERNOR			
25	40337400	1	PROTEZIONE	PROTECTION	SCHUTZ	GUARD	85		
25	40265801	1	PROTEZIONE	PROTECTION	SCHUTZ	GUARD	105		
25	40265901	1	PROTEZIONE	PROTECTION	SCHUTZ	GUARD	125 / 135		
26	32201200		BOCCOLA	DOUILLE	BUCHSE	BUSHING			
27	68129200		CAVALLOTTO	ARRETOIR	KLEMMSTÜCK	UBOLT			
28	12015100		COLTELLO A SPATOLA	COUTEAU	MESSER	KNIFE			
29	30082300	1	AGGANCIO	CROCHET	HAKEN	HOOK			
30	68136700	1	PULEGGIA	POULIE	RIEMENSCHLEIBE	PULLEY	Ø130 2 SPA F.55		
31	68058800	1	PULEGGIA	POULIE	RIEMENSCHLEIBE	PULLEY	Ø100 2 SPA F.55		
32	68058900	1	CALETTATORE	DOUILLE DE SERRAGE	SPANNBUCHSE	LOCKING DEVICE	Øi 25 Øe 55		
33	68059000	1	CALETTATORE	DOUILLE DE SERRAGE	SPANNBUCHSE	LOCKING DEVICE	Øi 30 Øe 55		
34	68094100	2	CINGHIA	COURROIE	KEILRIEMEN	BELT	XPA 932		
35	12010200		COLTELLO	COUTEAU	MESSER	KNIFE			
36	31042800		BOCCOLA	DOUILLE	BUCHSE	BUSHING			
37	60012900		VITE	VIS	SCHRAUBE	SCREW	TE 8x45 UNI 5737		
38	42086500	1	ROTORE	ROTOR	ROTOR	ROTOR	85		
38	42086600	1	ROTORE	ROTOR	ROTOR	ROTOR	105		
38	42086700	1	ROTORE	ROTOR	ROTOR	ROTOR	125		
38	42086800	1	ROTORE	ROTOR	ROTOR	ROTOR	135		
39	40255200	2	PROTEZIONE	PROTECTION	SCHUTZ	GUARD			
40	67010200	2	SUPPORTO	SUPPORT	HALTERUNG	SUPPORT	UCF 206		
41	62010400	8	DADO	ECROU	MUTTER	NUT	M10x1,5 AUTOBLOCC.		
42	60023500	8	VITE	VIS	SCHRAUBE	SCREW	TE 10x35 UNI 5739 8.8 ZNT		
43	12016600		COLTELLO "VERTICUT"	COUTEAU "VERTICUT"	VERTICUT MESSER	VERTICUT KNIFE			
44	31067500		BOCCOLA	DOUILLE	BUCHSE	BUSHING			

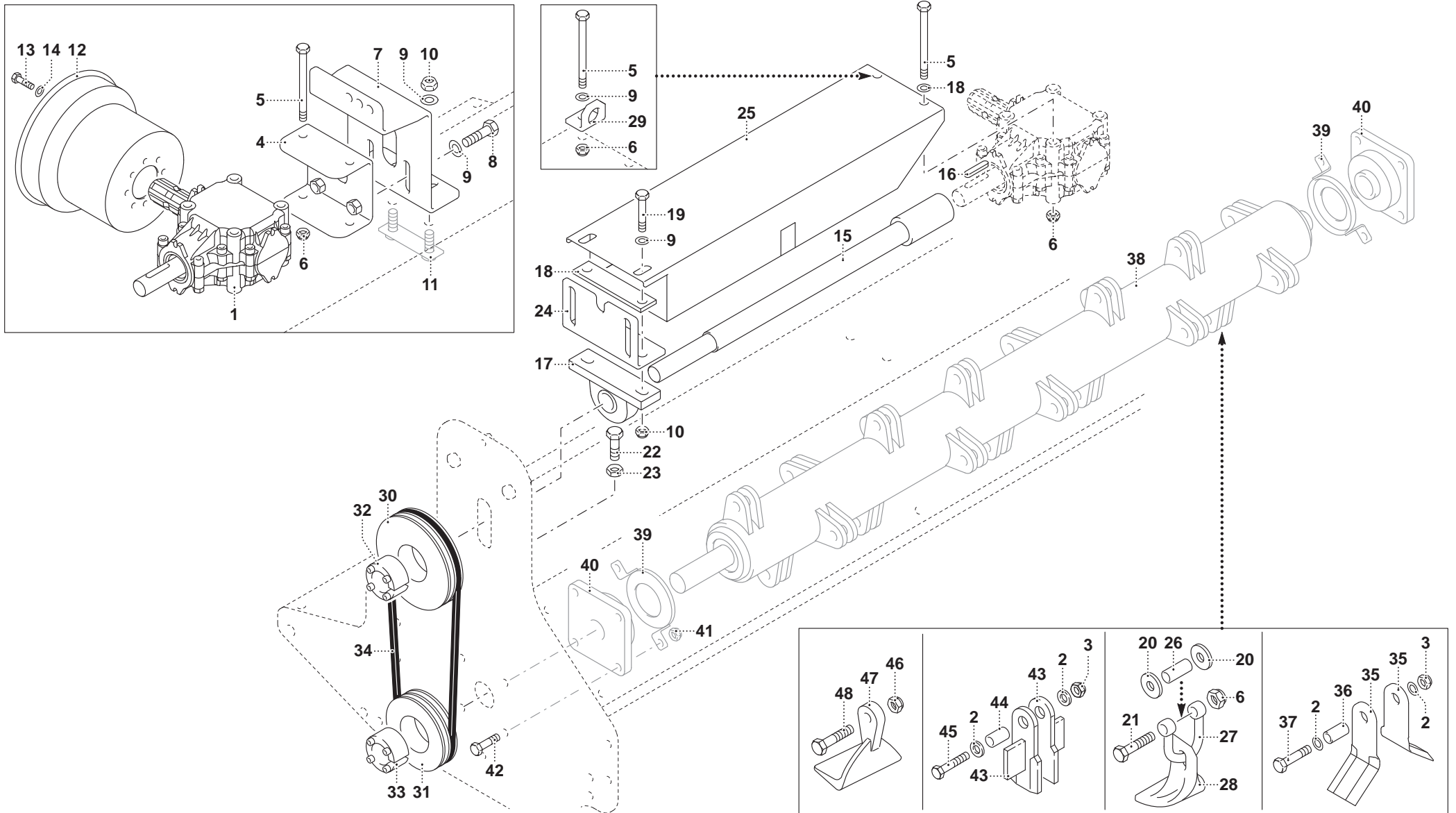

MURATORI MT11

TAV. 2.0

POS.	N° CODICE	Q.	DESCRIZIONE	DESIGNATION	BENENNUNG	DESCRIPTION	DESIGNAZIONE	Da matr. De nr. serie Vom Seriennr. From serial nr.	Fino matr. Jusqu'au nr. serie Bis Seriennr. Up to serial nr.
45	60034400		VITE	VIS	SCHRAUBE	SCREW	TE 8x55 UNI 5737		
46	62010800		DADO	ECROU	MUTTER	NUT	M14x2 AUTOBLOCC.		
47	12019400		MAZZA	MARTEAUX	HAMMER	HAMMER			
48	60021900		VITE	VIS	SCHRAUBE	SCREW	TE 14x50 UNI 5737		

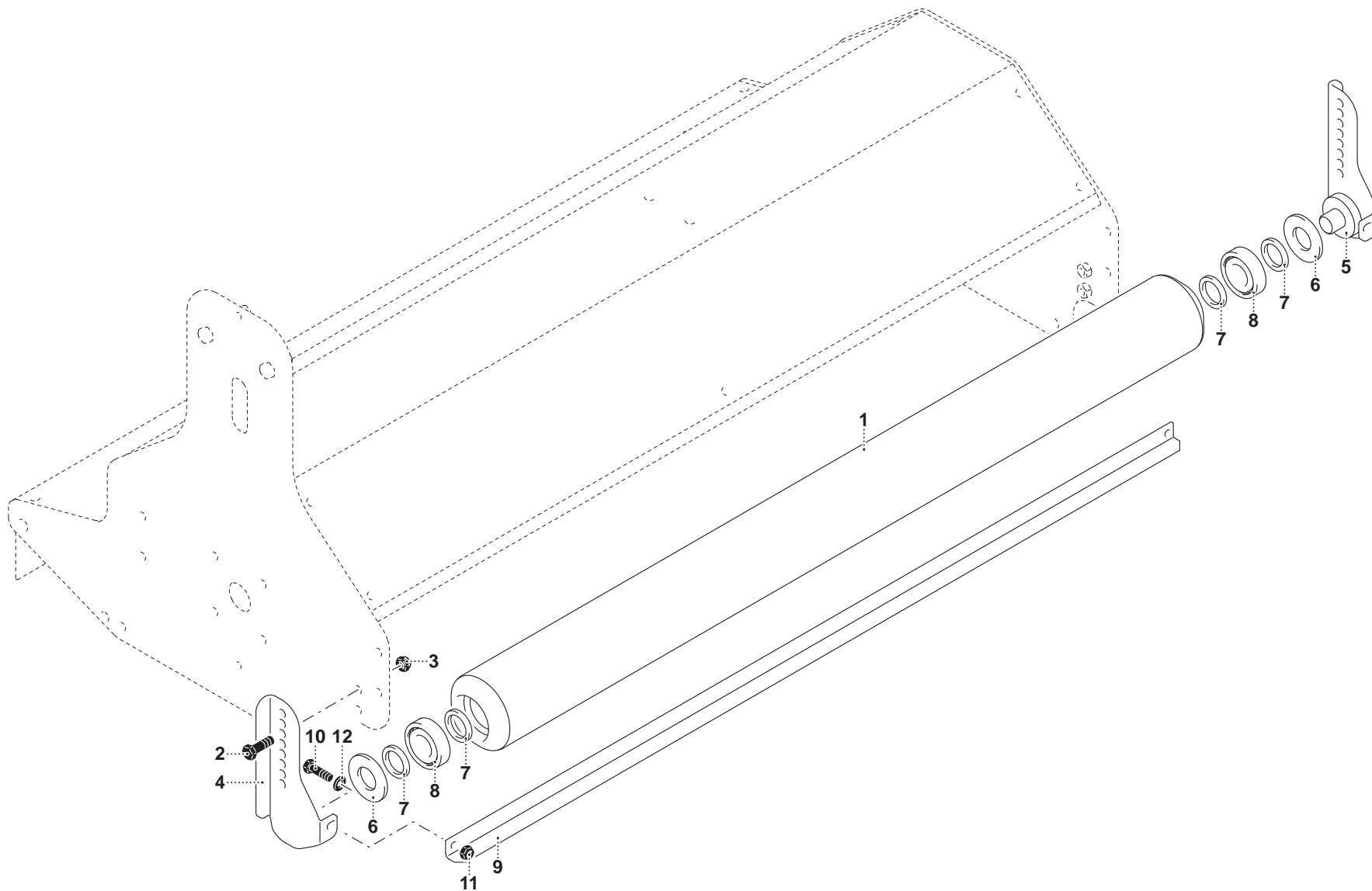

MURATORI MT11

TAV. 3.0

POS.	N° CODICE	Q.	DESCRIZIONE	DESIGNATION	BENENNUNG	DESCRIPTION	DESIGNAZIONE	Da matr. De nr. serie Vom Seriennr. From serial nr.	Fino matr. Jusqu'au nr. serie Bis Seriennr. Up to serial nr.
1	42070800	1	RULLO	ROULEAU	WALZE	ROLLER	85		
1	42071000	1	RULLO	ROULEAU	WALZE	ROLLER	105		
1	42079200	1	RULLO	ROULEAU	WALZE	ROLLER	125		
1	42087100	1	RULLO	ROULEAU	WALZE	ROLLER	135		
2	60017900	4	VITE	VIS	SCHRAUBE	SCREW	TE 10x25 UNI 5739 ZNT		
3	62010400	2	DADO	ECROU	MUTTER	NUT	M10 AUTOBLOCC.		
4	40328100	1	SUPPORTO SX	SUPPORT (G)	HALTER (L)	SUPPORT (LH)			
5	40328200	1	SUPPORTO DX	SUPPORT (D)	HALTERUNG (R)	SUPPORT (RH)			
6	39200500	2	DISCO	DISQUE	SCHEIBE	DISC			
7	68028400	4	SPESSORE	EPAISSEUR	DISTANZRING	SPACER	25 x 35 x 1		
8	67017500	2	CUSCINETTO	ROULEMENT	LAGER	BEARING	6305 2 RS		
9	34030300	1	RASCHIARULLO	GRATTOIR	ABSTREIFER	SCRAPER	85		
9	34012300	1	RASCHIARULLO	GRATTOIR	ABSTREIFER	SCRAPER	105		
9	34032100	1	RASCHIARULLO	GRATTOIR	ABSTREIFER	SCRAPER	125		
9	34033500	1	RASCHIARULLO	GRATTOIR	ABSTREIFER	SCRAPER	135		
10	60022800	2	VITE	VIS	SCHRAUBE	SCREW	TE 8x20 UNI 5739 ZNT		
11	62002900	2	DADO	ECROU	MUTTER	NUT	M8 UNI 5588		
12	61002500	2	RONDELLA	RONDELLE	SCHEIBE	WASHER	ELASTICA Ø8 UNI 1751		

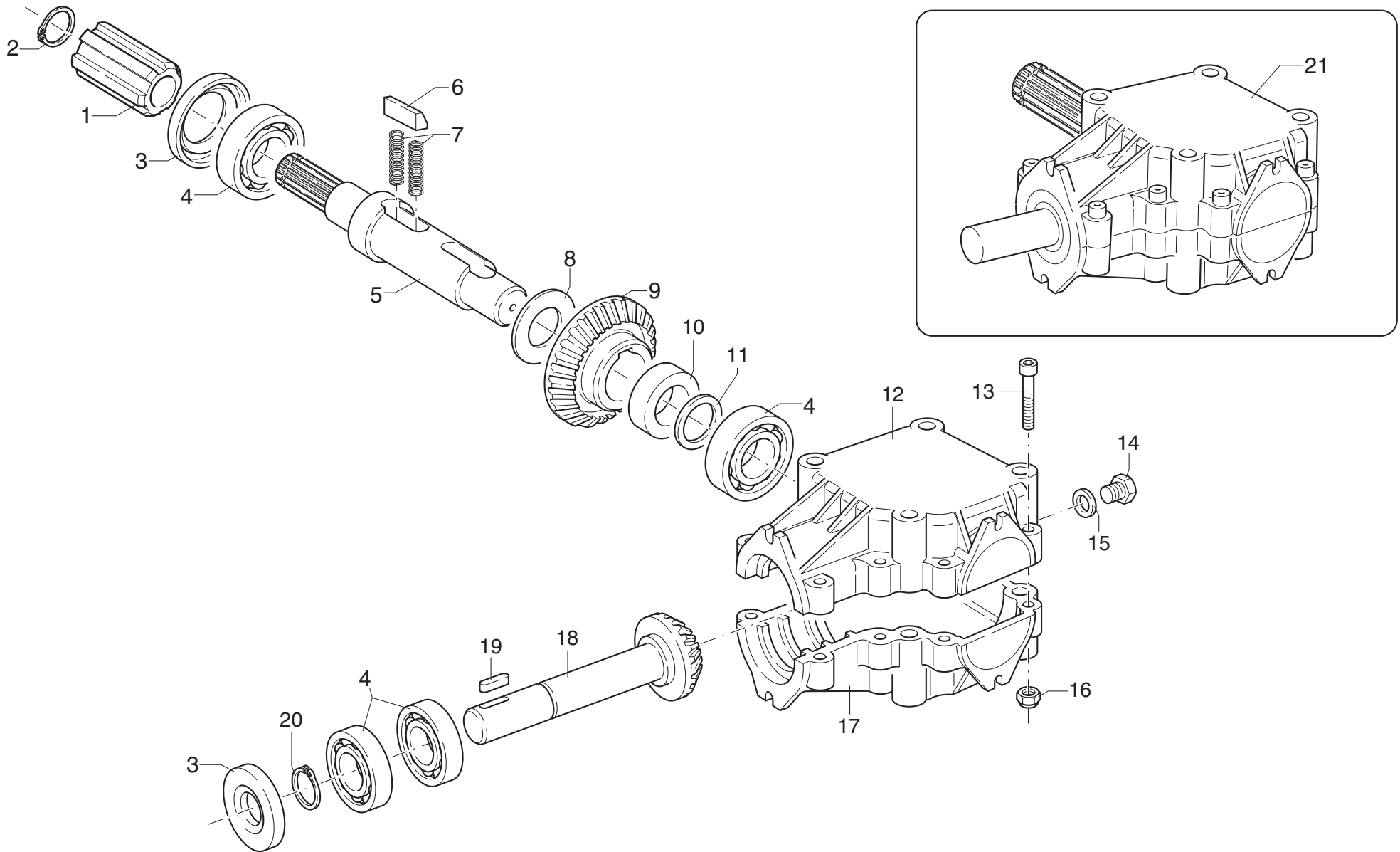

MURATORI MT11

TAV. 4.0

POS.	N° CODICE	Q.	DESCRIZIONE	DESIGNATION	BENENNUNG	DESCRIPTION	DESIGNAZIONE	Da matr. De nr. serie Vom Seriennr. From serial nr.	Fino matr. Jusqu'au nr. serie Bis Seriennr. Up to serial nr.
1	32175900	1	MANICOTTO	MANCHON	MITNEHMER	SLEEVE			
2	63005900	1	ANELLO ELASTICO	BAGUE	SPANNRING	SNAP-RING	Ø19 E UNI 7435		
3	66008700	2	ANELLO TENUTA	JOINT D'ETANCHEITE	DICHTUNGSRING	JUNT RING	25 x 47 x 7		
4	67012700	4	CUSCINETTO	ROULEMENT	LAGER	BEARING	6205		
5	31079200	1	ALBERO	ARBRE	WELLE	SHAFT			
6	65002800	1	LINGUETTA	CLAVETTE	FEDER	KEY	10 x 10 x 25		
7	68087400	2	MOLLA	RESSORT	FEDER	SPRING			
8	68068800	1	SPESSORE	EPAISSEUR	DISTANZRING	SPACER	30 x 42 x 1		
9	10044500	1	COPPIA CONICA	COUPLE CONIQUE	KEGELRADGETRIEBEPAAR	BEVEL GEAR PAIR			
10	32176000	1	DISTANZIALE	ENTRETOISE	DISTANZSTÜCK	SPACER			
11	68087500		SPESSORE	EPAISSEUR	DISTANZRING	SPACER	35 x 25		
12	03001200	1	SEMISCATOLA	DEMI-CARTER	HÄLFTE GEHÄUSE	HALF CASE			
13	60020800	8	VITE	VIS	SCHRAUBE	SCREW	TCEI 8 x 45 UNI 5931		
14	68051300	1	TAPPO	BOUCHON	STOPFEN	PLUG			
15	66011100	1	ANELLO TENUTA	JOINT D'ETANCHEITE	DICHTUNGSRING	JUNT RING	O.R. 3062		
16	62002900	8	DADO	ECROU	MUTTER	NUT	M8 UNI 5588		
17	03001100	1	SEMISCATOLA	DEMI-CARTER	HÄLFTE GEHÄUSE	HALF CASE			
18	10044500	1	COPPIA CONICA	COUPLE CONIQUE	KEGELRADGETRIEBEPAAR	BEVEL GEAR PAIR			
19	65000900	1	LINGUETTA	CLAVETTE	FEDER	KEY	8 x 7 x 40		
20	63002200	1	ANELLO ELASTICO	ARRETOIR	SPANNRING	SNAP-RING	Ø25 E UNI 7435		
21	46036600	1	MOLTIPLICATORE ORARIO	BOITIER (ROT. STANDARD)	RECHTSDR. GETRIEBE	CLOCKWISE GEAR BOX			
21	46036700	1	MOLTIPLICATORE ANTIORARIO	BOITIER (ROT. INVERSE)	LINKSDR. GETRIEBE	COUNTERCL. GEAR BOX			

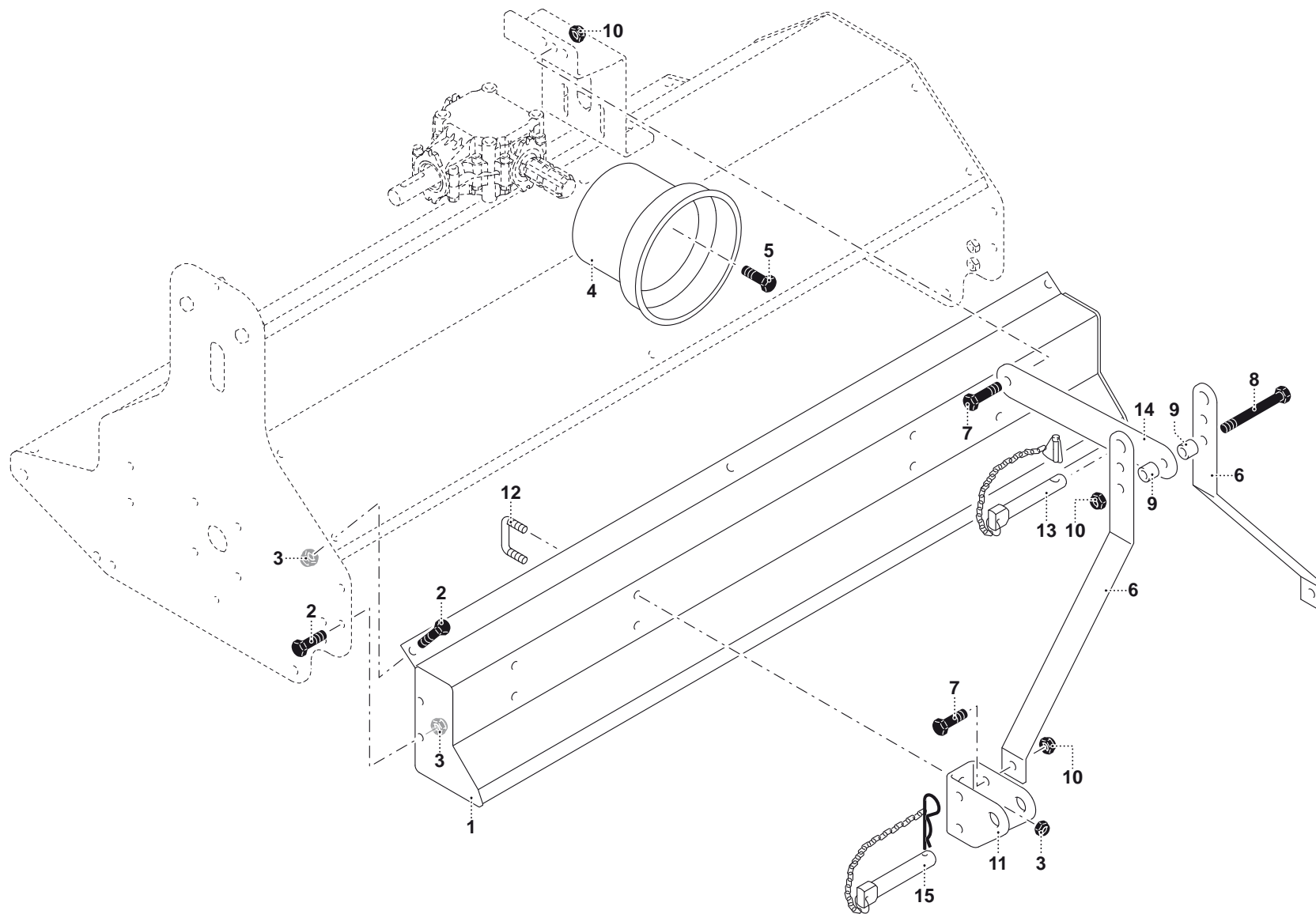

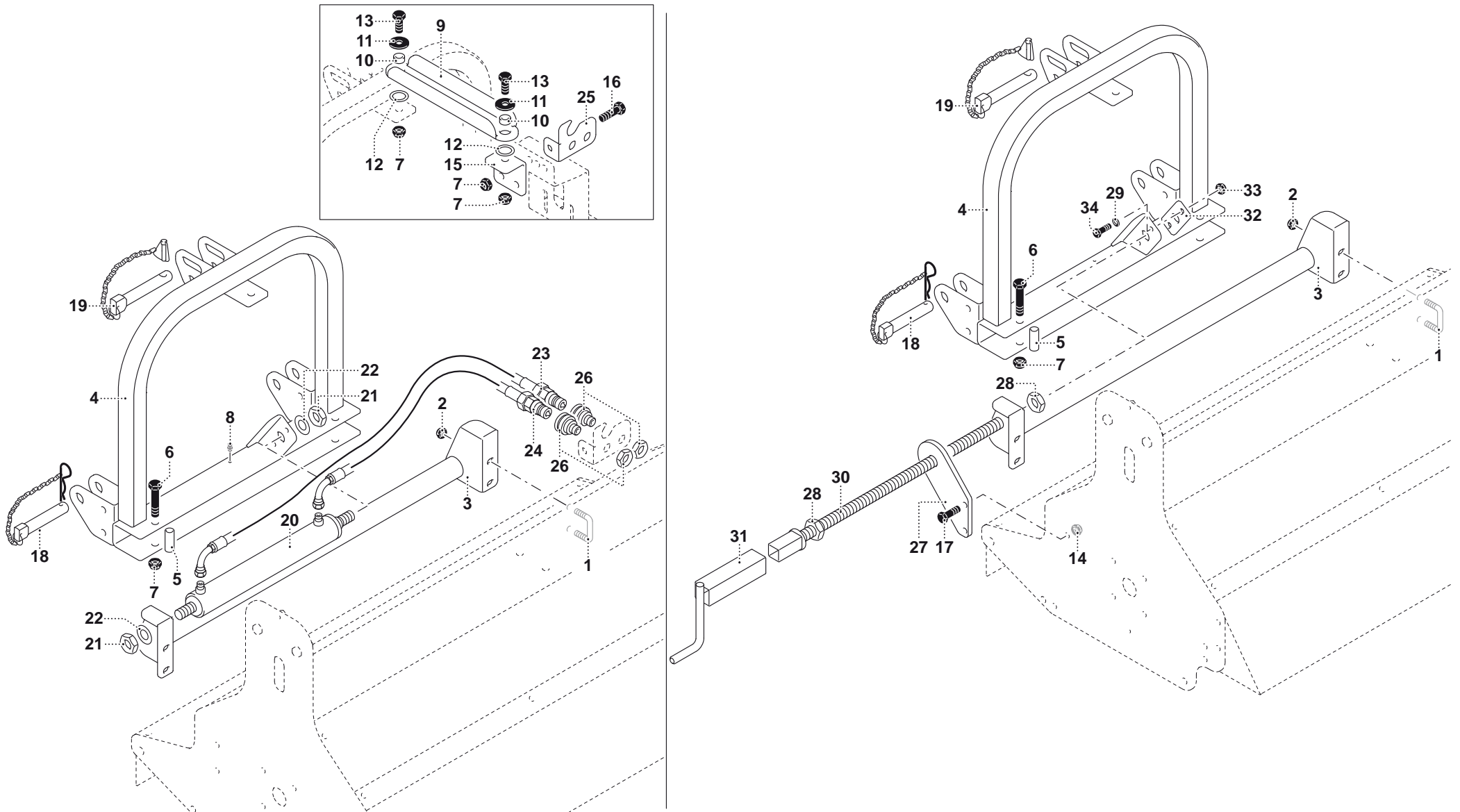

MURATORI MT11

TAV. 6.0

POS.	N° CODICE	Q.	DESCRIZIONE	DESIGNATION	BENENNUNG	DESCRIPTION	DESIGNAZIONE	Da matr. De nr. serie Vom Seriennr. From serial nr.	Fino matr. Jusqu'au nr. serie Bis Seriennr. Up to serial nr.
1	38027900	2	CAVALLOTTO	ARRETOIR	KLEMMSTÜCK	UBOLT	M10		
2	62010400	4	DADO	ECROU	MUTTER	NUT	M10 AUTOBLOCC.		
3	40337900	1	TELAIO	CHASSIS	RAHMEN	FRAME			
4	40337800	1	CARRELLO	CHARIOT	WAGEN	CAR			
5	32205500	2	DISTANZIALE	ENTRETOISE	DISTANZSTÜCK	SPACER			
6	60010100	2	VITE	VIS	SCHRAUBE	SCREW	TE 12x65 UNI 5737 ZNT		
7	62010600	6	DADO	ECROU	MUTTER	NUT	M12 AUTOBLOCC.		
8	64000200	1	INGRASSATORE	GRAISSEUR	SCHMIERNIPPEL	GREASE FITTING	M6		
9	39368400	1	TIRANTE	TIRANT	STANGE	TIEROD			
10	32183500	2	DISTANZIALE	ENTRETOISE	DISTANZSTÜCK	SPACER			
11	61007500	2	RONDELLA	RONDELLE	SCHEIBE	WASHER	PIANA Ø12		
12	68028400	2	SPESSORE	EPAISSEUR	DISTANZRING	SPACER	35 x 25 x 1		
13	60021200	2	VITE	VIS	SCHRAUBE	SCREW	TE 12x35 UNI 5739 ZNT		
14	62011000	2	DADO	ECROU	MUTTER	NUT	M10 AUTOBLOCC.		
15	39367700	1	SUPPORTO	SUPPORT	HALTERUNG	SUPPORT			
16	60023000	2	VITE	VIS	SCHRAUBE	SCREW	TE 12x30 UNI 5739 ZNT		
17	60021300	2	VITE	VIS	SCHRAUBE	SCREW	TE 10x30 UNI 5739 ZNT		
18	68062300	2	PERNO	PIVOT	BOLZEN	PIN			
19	68062000	1	PERNO	PIVOT	BOLZEN	PIN			
20	68083800	1	CILINDRO	CYLINDRE	ZYLINDER	CYLINDER			
21	62008300	2	DADO	ECROU	MUTTER	NUT	M20 MEDIO UNI 5588 ZNT		
22	61006300	2	RONDELLA	RONDELLE	SCHEIBE	WASHER	ELASTICA Ø20 UNI 1751 ZNT		
23	68048400	1	TUBO	TUBE	ROHR	TUBE			
24	68048300	1	TUBO	TUBE	ROHR	TUBE			
25	39358200	1	SUPPORTO	SUPPORT	HALTERUNG	SUPPORT			
26	68123100	2	INNESTO FEMMINA	ENCLACHEMENT FEMME	WEIB KUPPLUNG	FEMALE ENGAGEMENT			

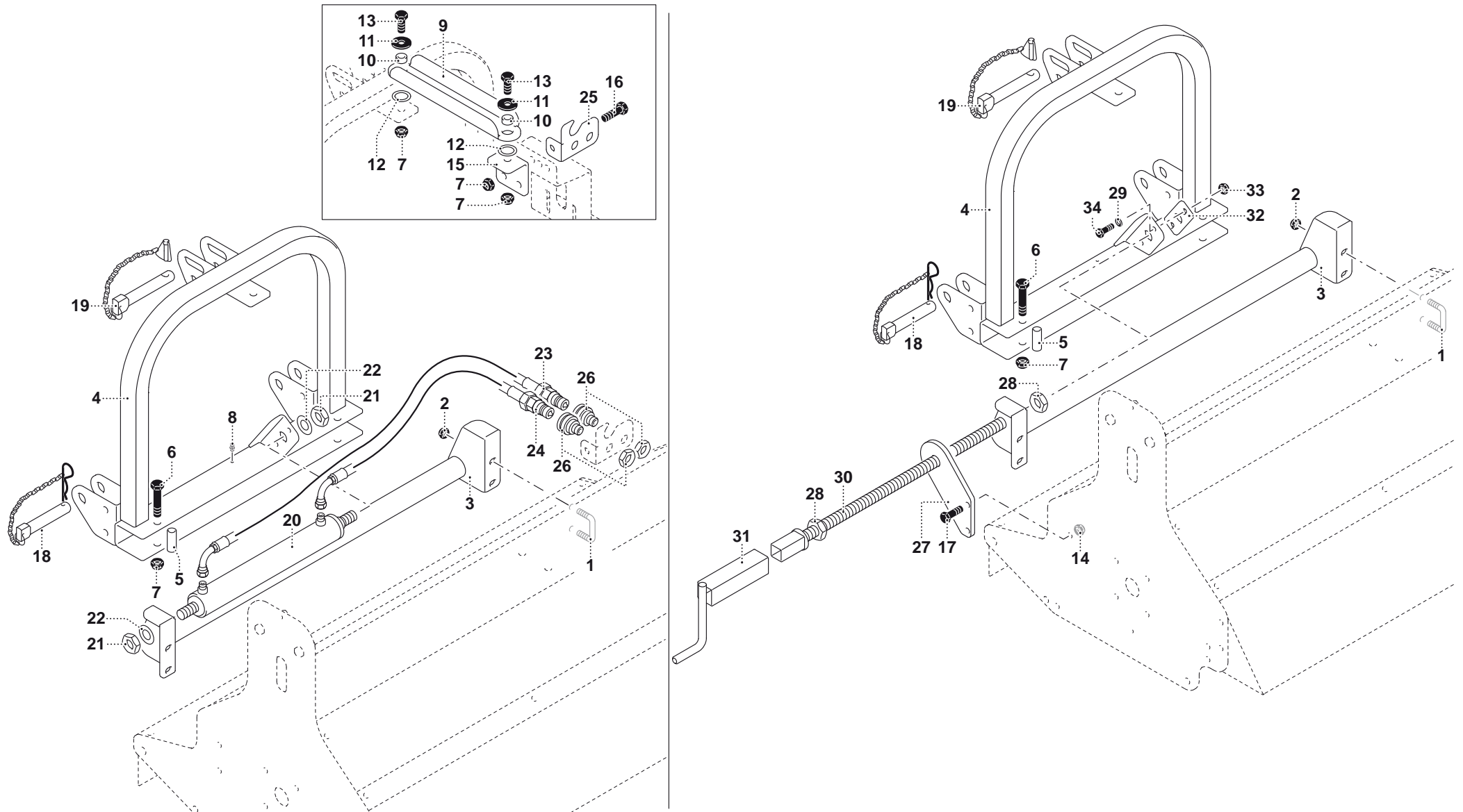

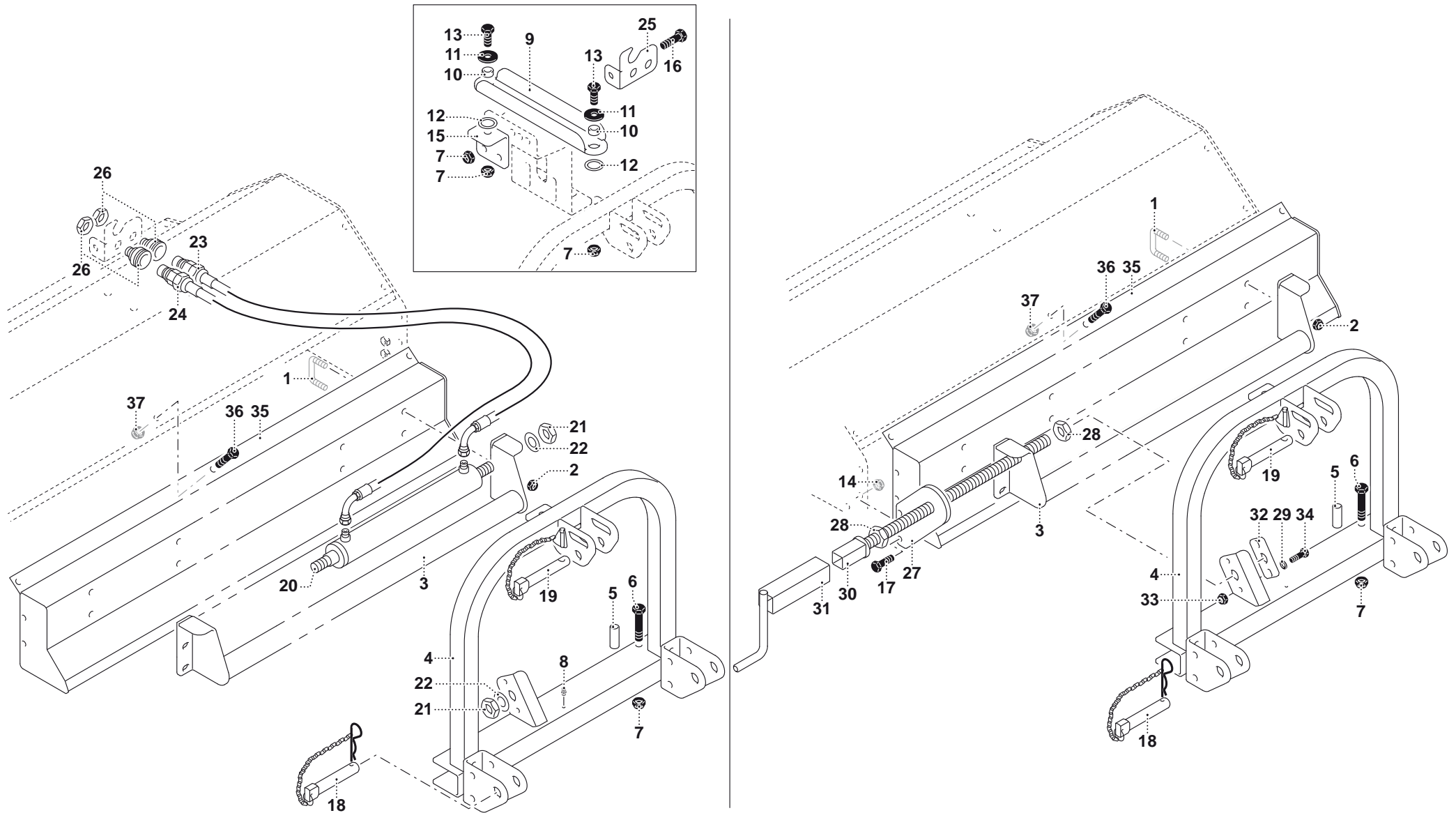

MURATORI MT11

TAV. 7.0

POS.	N° CODICE	Q.	DESCRIZIONE	DESIGNATION	BENENNUNG	DESCRIPTION	DESIGNAZIONE	Da matr. De nr. serie Vom Seriennr. From serial nr.	Fino matr. Jusqu'au nr. serie Bis Seriennr. Up to serial nr.
1	38027900	2	CAVALLOTTO	ARRETOIR	KLEMMSTÜCK	UBOLT	M10		
2	62010400	4	DADO	ECROU	MUTTER	NUT	M10 AUTOBLOCC.		
3	40337900	1	TELAIO	CHASSIS	RAHMEN	FRAME			
4	40337800	1	CARRELLO	CHARIOT	WAGEN	CAR			
5	32205500	2	DISTANZIALE	ENTRETOISE	DISTANZSTÜCK	SPACER			
6	60010100	2	VITE	VIS	SCHRAUBE	SCREW	TE 12x65 UNI 5737 ZNT		
7	62010600	6	DADO	ECROU	MUTTER	NUT	M12 AUTOBLOCC.		
8	64000200	1	INGRASSATORE	GRAISSEUR	SCHMIERNIPPEL	GREASE FITTING	M6		
9	39368400	1	TIRANTE	TIRANT	STANGE	TIEROD			
10	32183500	2	DISTANZIALE	ENTRETOISE	DISTANZSTÜCK	SPACER			
11	61007500	2	RONDELLA	RONDELLE	SCHEIBE	WASHER	PIANA Ø12		
12	68028400	2	SPESSORE	EPAISSEUR	DISTANZRING	SPACER	35 x 25 x 1		
13	60021200	2	VITE	VIS	SCHRAUBE	SCREW	TE 12x35 UNI 5739 ZNT		
14	62011000	2	DADO	ECROU	MUTTER	NUT	M10 AUTOBLOCC.		
15	39367700	1	SUPPORTO	SUPPORT	HALTERUNG	SUPPORT			
16	60023000	2	VITE	VIS	SCHRAUBE	SCREW	TE 12x30 UNI 5739 ZNT		
17	60021300	2	VITE	VIS	SCHRAUBE	SCREW	TE 10x30 UNI 5739 ZNT		
18	68062300	2	PERNO	PIVOT	BOLZEN	PIN			
19	68062000	1	PERNO	PIVOT	BOLZEN	PIN			
20	68083800	1	CILINDRO	CYLINDRE	ZYLINDER	CYLINDER			
21	62008300	2	DADO	ECROU	MUTTER	NUT	M20 MEDIO UNI 5588 ZNT		
22	61006300	2	RONDELLA	RONDELLE	SCHEIBE	WASHER	ELASTICA Ø20 UNI 1751 ZNT		
23	68048400	1	TUBO	TUBE	ROHR	TUBE			
24	68048300	1	TUBO	TUBE	ROHR	TUBE			
25	39358200	1	SUPPORTO	SUPPORT	HALTERUNG	SUPPORT			
26	68123100	2	INNESTO FEMMINA	ENCLenchement FEMME	WEIB KUPPLUNG	FEMALE ENGAGEMENT			

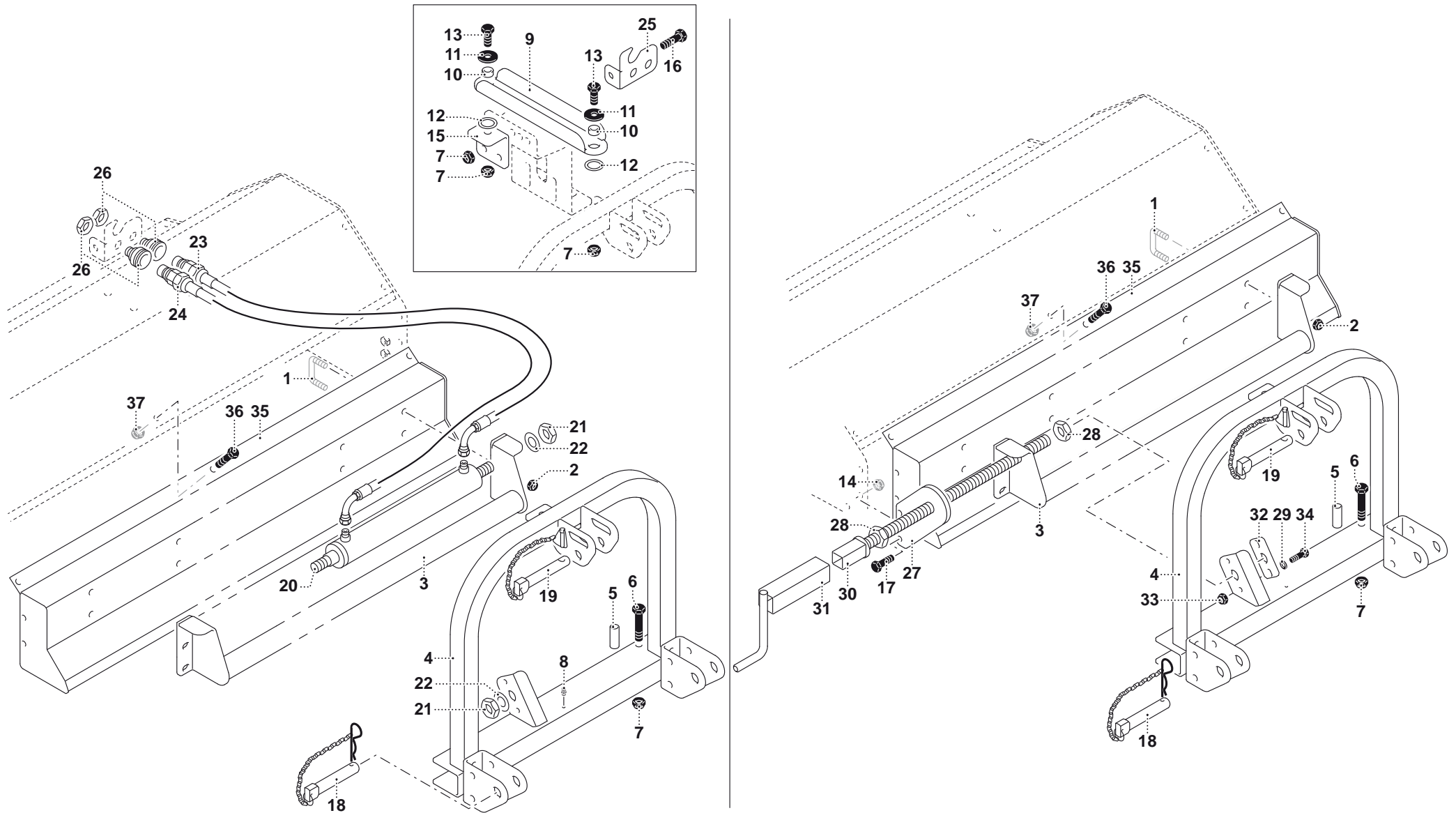

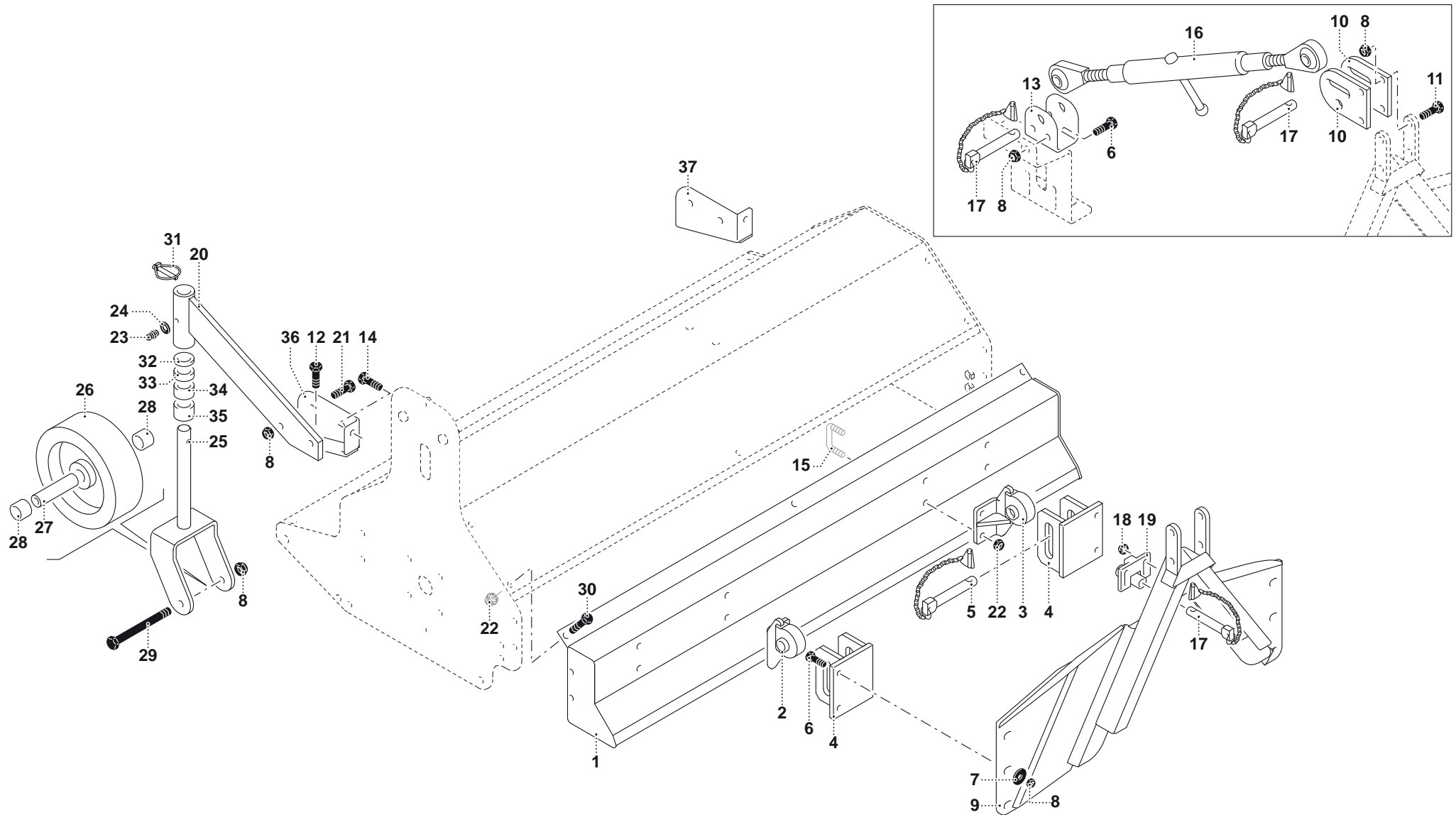

MURATORI MT11

TAV. 8.0

POS.	N° CODICE	Q.	DESCRIZIONE	DESIGNATION	BENENNUNG	DESCRIPTION	DESIGNAZIONE	Da matr. De nr. serie Vom Seriennr. From serial nr.	Fino matr. Jusqu'au nr. serie Bis Seriennr. Up to serial nr.
1	40336800	1	ATTACCO	ATTACHE	ANSCHLUSS	ATTACHMENT	85		
1	40336900	1	ATTACCO	ATTACHE	ANSCHLUSS	ATTACHMENT	105		
1	40337000	1	ATTACCO	ATTACHE	ANSCHLUSS	ATTACHMENT	125		
1	40337100	1	ATTACCO	ATTACHE	ANSCHLUSS	ATTACHMENT	135		
2	40342400	1	AGGANCIOS SX	CROCHET (G)	HAKEN (L)	HOOK (LH)			
3	40342500	1	AGGANCIOS DX	CROCHET (D)	HAKEN (R)	HOOK (RH)			
4	40295100	2	STAFFA	BRIDE	BÜGEL	BRACKET			
5	68062000	2	PERNO	PIVOT	BOLZEN	PIN			
6	60020400	6	VITE	VIS	SCHRAUBE	SCREW	TE 12x25 UNI 5739 ZNT		
7	61005000	4	RONDELLA	RONDELLE	SCHEIBE	WASHER	PIANA Ø12 UNI 6592 ZNT		
8	62010600	16	DADO	ECROU	MUTTER	NUT	M12 AUTOBLOCC.		
9	40308900	1	ATTACCO RAPIDO	ATTELAGE RAPIDE	SCHNELLKUPPLUNG	QUICKLINKAGE			
10	39300800	2	STAFFA	BRIDE	BÜGEL	BRACKET			
11	60021200	4	VITE	VIS	SCHRAUBE	SCREW	TE 12x35 UNI 5739 ZNT		
12	60017900	4	VITE	VIS	SCHRAUBE	SCREW	TE 10x25 UNI 5739 ZNT		
13	39377800	1	STAFFA	BRIDE	BÜGEL	BRACKET			
14	60023500	2	VITE	VIS	SCHRAUBE	SCREW	TE 10x35 UNI 5739 ZNT		
15	38027900	2	CAVALLOTTO	ARRETOIR	KLEMMSTÜCK	UBOLT	M10		
16	68020300	1	BRACCIO	BRAS	ARM	ARM			
17	68062000	3	PERNO	PIVOT	BOLZEN	PIN			
18	62010200	2	DADO	ECROU	MUTTER	NUT	M8 AUTOBLOCC.		
19	40246700	1	BLOCCAGGIO	BLOCAGE	BEFESTIGUNG	LOCK			
20	40234200	2	STAFFA	BRIDE	BÜGEL	BRACKET			
21	60023000	4	VITE	VIS	SCHRAUBE	SCREW	TE 12x30 UNI 5739 ZNT		
22	62010400	7	DADO	ECROU	MUTTER	NUT	M10 AUTOBLOCC.		
23	64000200	2	INGRASSATORE	GRAISSEUR	SCHMIERNIPPEL	GREASE FITTING	M6x1		

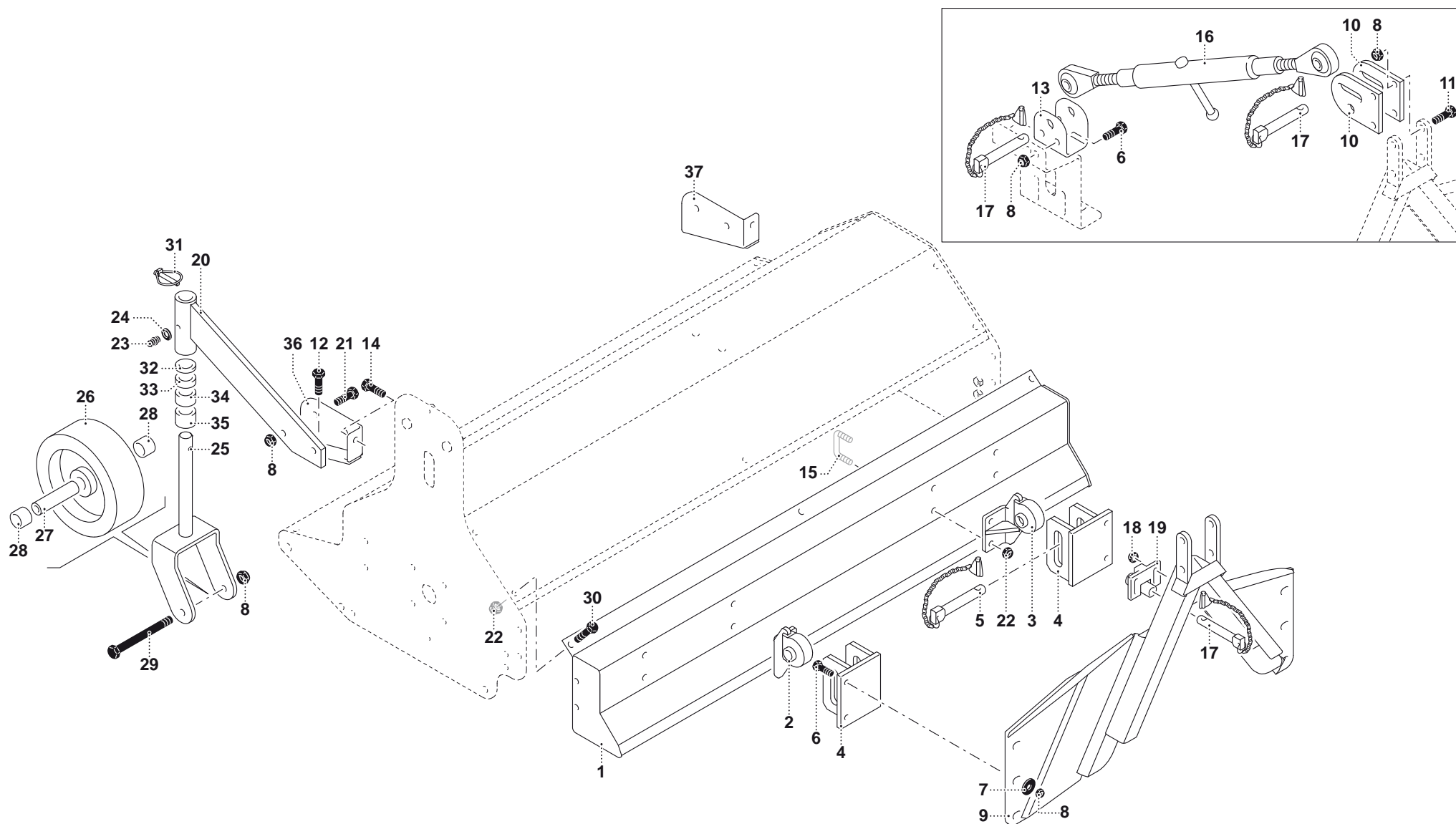

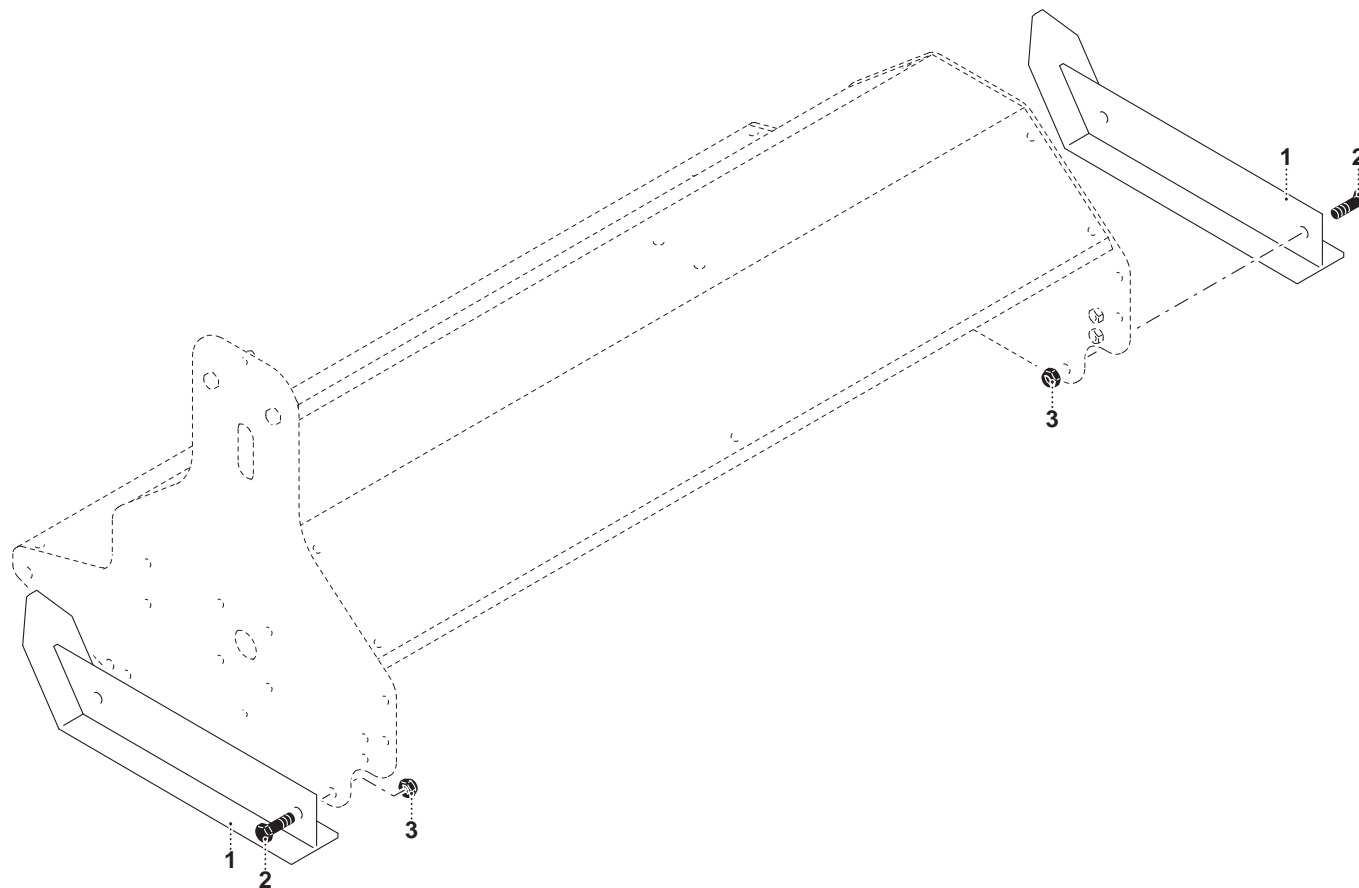

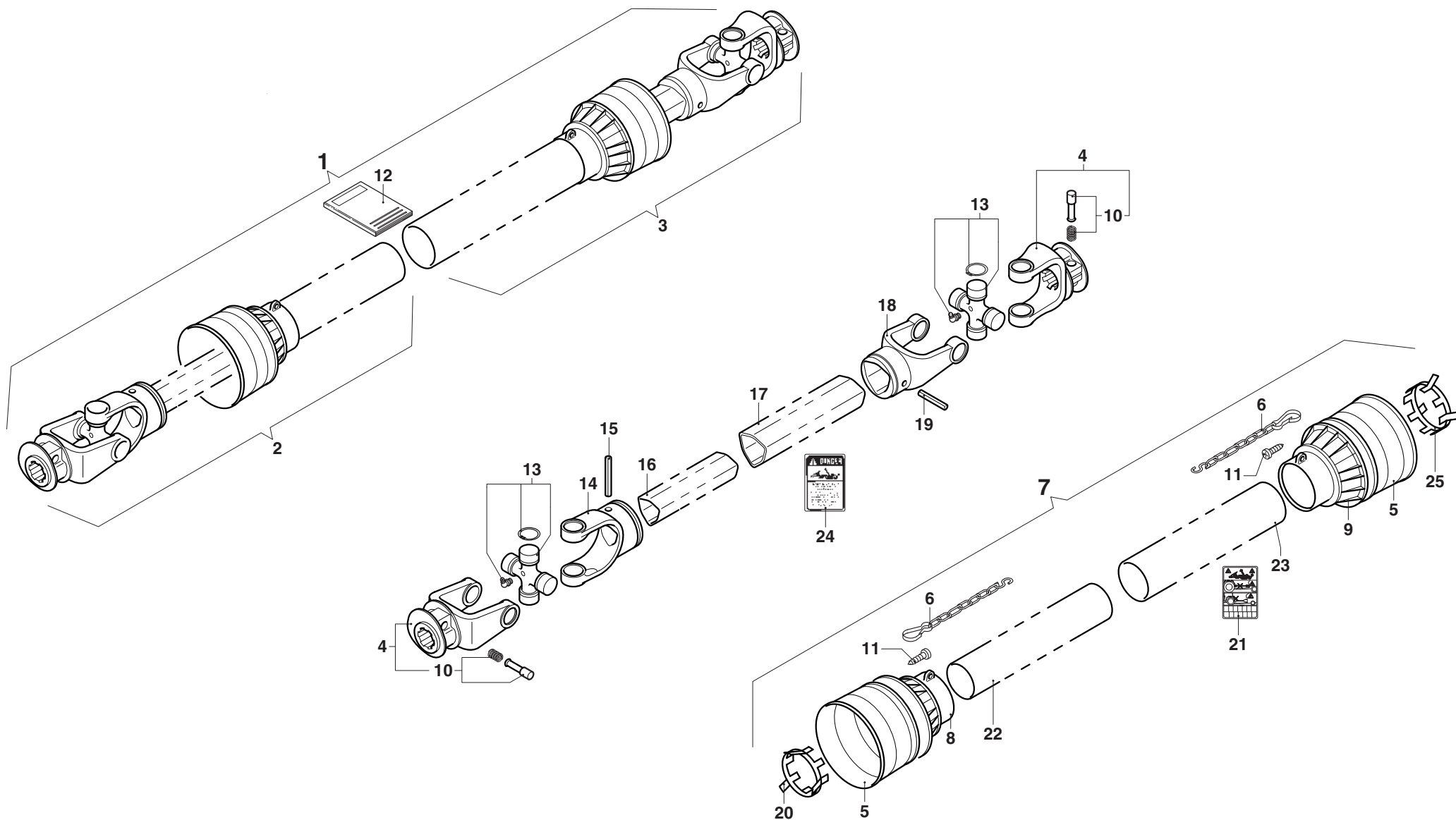

MURATORI MT11

TAV. 10.0

POS.	N° CODICE	Q.	DESCRIZIONE	DESIGNATION	BENENNUNG	DESCRIPTION	DESIGNAZIONE	Da matr. De nr. serie Vom Seriennr. From serial nr.	Fino matr. Jusqu'au nr. serie Bis Seriennr. Up to serial nr.
1	AB107SF	1	ALBERO CARDANICO COMPLETO	ARBRE A JOINTS DE CARDAN	KARDANWELLE	PTO SHAFT			
2	B1N051CE1	1	SEMIALBERO INTERNO	DEMI-ARBRE INTERIEUR	INNENHALBWELLE	INTERNAL HALF SHAFT			
3	B1N051CE2	1	SEMIALBERO ESTERNO	DEMI-ARBRE EXTERIEUR	AUSSENHALBWELLE	EXTERNAL HALF SHAFT			
4	0800103	2	FORCELLA	FOURCHE	GABEL	YOKE			
5	021902C001	2	CUFFIA	CAPOUCHON	HAUBE	GUARD			
6	0252000001	2	CATENA	CHAINE	KETTE	CHAIN			
7	083CE01051	1	PROTEZIONE	PROTECTION	SCHUTZ	GUARD			
8	025402C002	1	PROTEZIONE INTERNA	PROTECTION INTERIEURE	INNENSCHUTZ	INTERNAL GUARD			
9	025402C001	1	PROTEZIONE ESTERNA	PROTECTION EXTERIEURE	AUSSENSCHUTZ	EXTERNAL GUARD			
10	0986014047	2	PULSANTE	BOUTON	DRUCKKNOPF	PUSH BOTTON			
11	0998052242	6	VITE	VIS	SCHRAUBE	SCREW			
12	09872101	1	MANUALE ISTRUZIONI	MANUEL D'UTILISATION ET D'ENTRETIEN	BETRIEBS- UND WARTUNGSANLEITUNG	USE AND MAINTENANCE MANUAL			
13	08201	2	CROCIERA	CROISILLON	KREUZSTÜCK	SPIDER			
14	08001011	1	FORCELLA	FOURCHE	GABEL	YOKE			
15	098700840	1	SPINA ELASTICA	GOUPILLE ELASTIQUE	SPANNSTIFT	ELASTIC PIN			
16	09881263100	1	TUBO INTERNO	TUBE INTERIEUR	INNENROHR	INTERNAL TUBE			
17	09881322100	1	TUBO ESTERNO	TUBE EXTERIEUR	AUSSENROHR	EXTERNAL TUBE			
18	08001021	1	FORCELLA	FOURCHE	GABEL	YOKE			
19	098700845	1	SPINA ELASTICA	GOUPILLE ELASTIQUE	SPANNSTIFT	ELASTIC PIN			
20	025501C002	1	GHIERA	FRETTE	NUTMUTTER	RING NUT			
21	09872010	1	ETICHETTA	ETIQUETE	ETIKETT	LABEL			
22	0988955NB1051	1	TUBO INTERNO	TUBE INTERIEUR	INNENROHR	INTERNAL TUBE			
23	0988961NB1051	1	TUBO ESTERNO	TUBE EXTERIEUR	AUSSENROHR	EXTERNAL TUBE			
24	09872006	1	ETICHETTA	ETIQUETE	ETIKETT	LABEL			
25	025501C001	1	GHIERA	FRETTE	NUTMUTTER	RING NUT			



MURATORI S.p.A.

Via Pavarello, 21 - 41051 Castelnuovo Rangone (MO) Italy - Tel. 059.5330611 Fax 059.537259

www.muratoriequip.it info@muratoriequip.it

Capitale sociale Euro 480.000 interamente versato

Registro Imprese di Modena

Codice fiscale e numero d'iscrizione: 00708860366

 **Miniwerk**tuigenshop