



# MURATORI

**TIPO-TYPE-TYP  
MT 30**

**CATALOGO RICAMBI**  
Catalogue Pièces Detachées  
Ersatzteilkatalog  
Spare Parts Catalogue  
Catálogo Recambios

EDIZIONE 09/2019



Per ordinare parti di ricambio specificare:

- tipo e matricola della macchina (apposti sulla macchina o sui documenti di acquisto);
- numero del riferimento del pezzo nel disegno (Pos.), numero della tavola (Tav.) e numero di codice

**N.B.:** le indicazioni destro o sinistro vengono date guardando la macchina da dietro.

*Pour les commandes de pièces de rechange veuillez spécifier:*

- *type et numéro de serie de la machine (indiqués sur la machine et sur le bon d'achat);*
- *numéro de référence du pièce sur le plan (Pos.), numéro du plan (Tav.) et numéro de code (codice)*

**N.B.:** *les indications droite ou gauche sont données en regardant la machine par derrière.*

Zum Bestellen von Ersatzteilen folgendes angeben:

- Typ und Serien-Nr. der Maschine (zu finden auf der Maschine oder der Einkaufspapieren);
- Bezug-Nr. des Ersatzteils auf der Zeichnung (Pos.), Zeichnungsnummer (Tav.) und Kodenummer (codice)

**N.B.:** die Angaben rechts und links verstehen sich so, dass man hinter der Maschine steht.

*When ordering spare parts specify:*

- *machine type and serial number (found on the machine or on the purchasing documents);*
- *reference number of the part on the relative drawing (Pos.), number of the drawing (Tav.) and part number (codice)*

**N.B.:** *right-hand or left-hand indications are made by viewing the machine from the rear.*

**TAV. 1.0**  
GRUPPO TELAIO  
ENSEMBLE CHASSIS  
SATZ FÜR RAHMEN  
KIT FOR FRAME

**TAV. 2.0**  
GRUPPO TRASMISSIONE ROTORE  
ENSEMBLE TRANSMISSION ROTOR  
SATZ FÜR DEN ROTARANTRIEB  
KIT FOR THE ROTOR TRANSMISSION

**TAV.3.0**  
GRUPPO RULLO POSTERIORE  
ENSEMBLE ROULEAU ARRIERE  
SATZ HINTERE WALZE  
KIT REAR ROLLER

**TAV. 4.0**  
GRUPPO MOLTIPLICATORE  
ENSEMBLE MULTIPLICATEUR  
SATZ FÜR GETRIEBE  
KIT FOR GEAR BOX

**TAV.5.0**  
ACCESSORI A COMPLETAMENTO  
OPTIONS D'ACHEVEMENT  
ZUBEHÖRE ZUR ERGANZUNG DER MASCHINE  
CHOICE OF EQUIPMENT COMPLETING MACHINE

**TAV.6.0**  
ACCESSORI A COMPLETAMENTO  
OPTIONS D'ACHEVEMENT  
ZUBEHÖRE ZUR ERGANZUNG DER MASCHINE  
CHOICE OF EQUIPMENT COMPLETING MACHINE

**TAV. 7.0**  
ALBERO CARDANICO COMPLETO - AB207SF  
ARBRE A JOINTS DE CARDAN - AB207SF  
KARDANWELLE - AB207SF  
PTO SHAFT - AB207SF

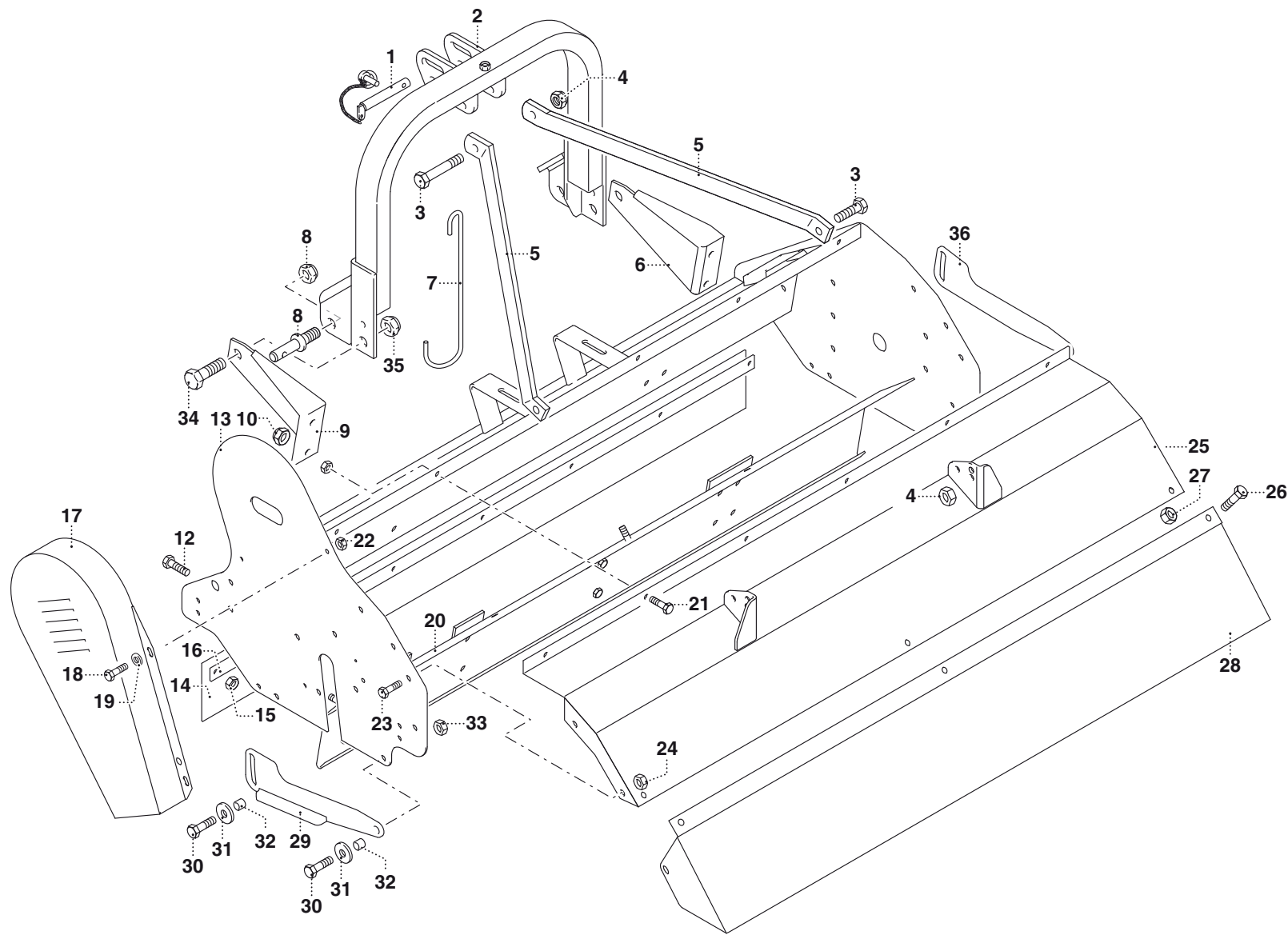

# MURATORI MT 30

# TAV. 1.0

POS.	N°	CODICE Q.	DESCRIZIONE	DESIGNATION	BENENNUNG	DESCRIPTION	DESIGNAZIONE	Da matr.	Fino matr.
								De nr. serie Vom Seriennr. From serial nr.	Jusqu'au nr. serie Bis Seriennr. Up to serial nr.
1	68062000	1	PERNO	PIVOT	BOLZEN	PIN			
2	40315700	1	ATTACCO	ATTACHE	ANSCHLUSS	ATTACHMENT			
3	60023000	4	VITE	VIS	SCHRAUBE	SCREW	TE 12 x 30 UNI 5739		
4	62010600	4	DADO	ECROU	MUTTER	NUT	M 12 x 1,75 AUTOBLOCC.		
5	30182800	2	TIRANTE	TIRANT	STANGE	TIEROD			
6	39169000	1	MENSOLA SX	CONSOLE (G)	KONSOLE (LINKS)	BRACKET (LH)			
7	38024500	1	GANCIO	CROCHET	HAKEN	HOOK			
8	68062500	2	PERNO	PIVOT	BOLZEN	PIN			
9	39168900	1	MENSOLA DX	CONSOLE (D)	KONSOLE (RECHTS)	BRACKET (RH)			
10	62010600	4	DADO	ECROU	MUTTER	NUT	M 12 x 1,75 AUTOBLOCC.		
11	62010400		DADO	ECROU	MUTTER	NUT	M 10 x 1,5 AUTOBLOCC.		
12	60022800		VITE	VIS	SCHRAUBE	SCREW	TE 8 x 20 UNI 5739		
13	41130000	1	TELAIO	CHASSIS	RAHMEN	FRAME	105		
13	41130100	1	TELAIO	CHASSIS	RAHMEN	FRAME	130		
13	41130200	1	TELAIO	CHASSIS	RAHMEN	FRAME	155		
13	41131100	1	TELAIO	CHASSIS	RAHMEN	FRAME	180		
14	68067800	1	BANDELLA	BANDE	BAND	STRAP	105		
14	68067900	1	BANDELLA	BANDE	BAND	STRAP	130		
14	68068000	1	BANDELLA	BANDE	BAND	STRAP	155		
14	68103400	1	BANDELLA	BANDE	BAND	STRAP	180		
15	62010200		DADO	ECROU	MUTTER	NUT	M 8 x 1,25 AUTOBLOCC.		
16	30125500	1	PIATTO	PLAQUE	PLATTE	PLATE	105		
16	30125600	1	PIATTO	PLAQUE	PLATTE	PLATE	130		
16	30125700	1	PIATTO	PLAQUE	PLATTE	PLATE	155		
16	30204000	1	PIATTO	PLAQUE	PLATTE	PLATE	180		
17	40227701	1	CARTER	CARTER	KETTENKASTEN	CASING			

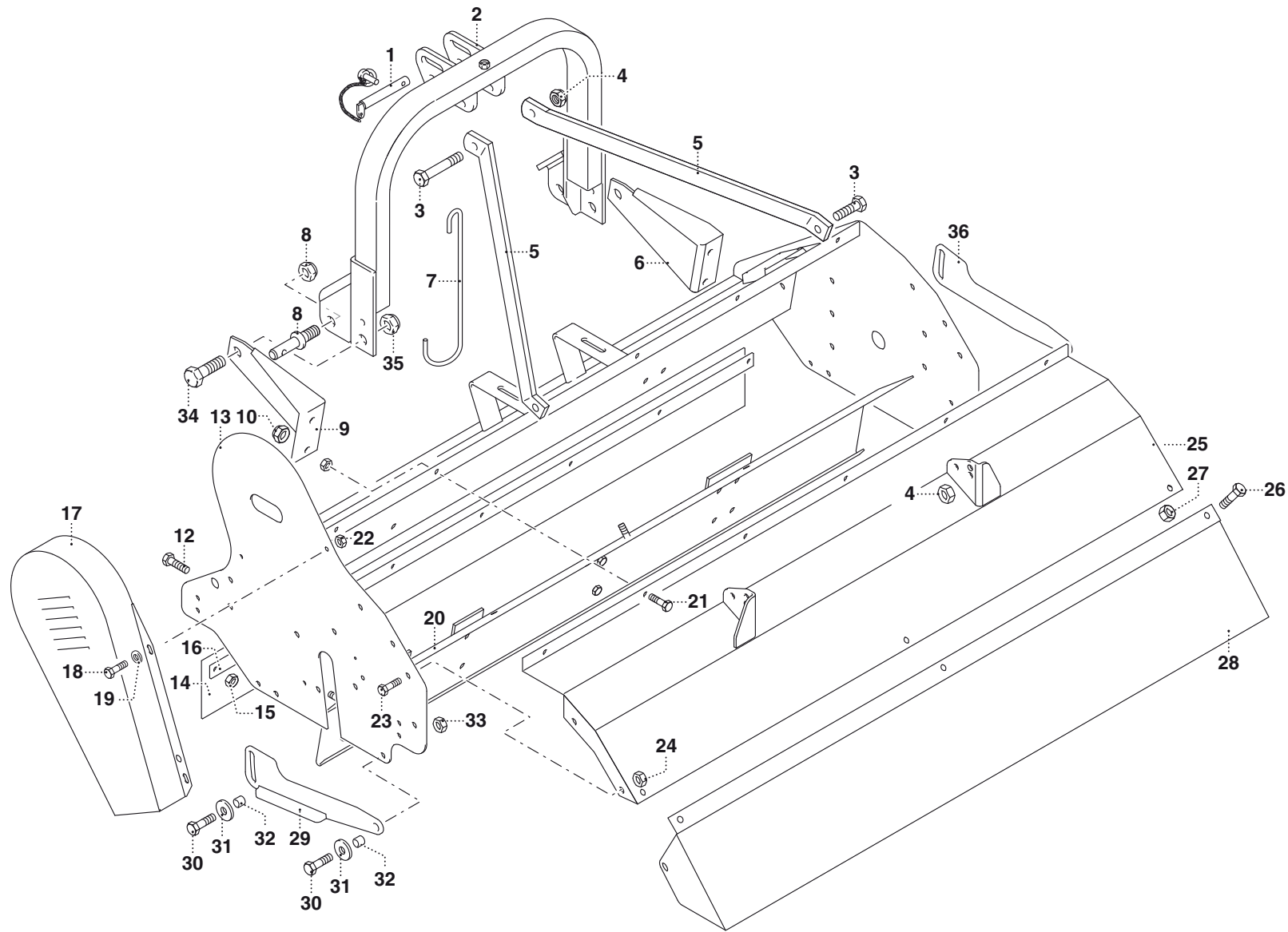

# MURATORI MT 30

TAV. 1.0

POS.	N°	CODICE Q.	DESCRIZIONE	DESIGNATION	BENENNUNG	DESCRIPTION	DESIGNAZIONE	Da matr.	Fino matr.
								De nr. serie Vom Seriennr. From serial nr.	Jusqu'au nr. serie Bis Seriennr. Up to serial nr.
18	60022800	4	VITE	VIS	SCHRAUBE	SCREW	TE 8 x 20 UNI 5739		
19	61006200	4	RONDELLA	RONDELLE	SCHEIBE	WASHER	PIANA Øi 9 Øe 24		
20	40283500	1	RINFORZO	RENFORT	VERSTÄRKUNG	REINFORCEMENT	105		
20	40283600	1	RINFORZO	RENFORT	VERSTÄRKUNG	REINFORCEMENT	130		
20	40283700	1	RINFORZO	RENFORT	VERSTÄRKUNG	REINFORCEMENT	155		
20	40317600	1	RINFORZO	RENFORT	VERSTÄRKUNG	REINFORCEMENT	180		
21	60021600		VITE	VIS	SCHRAUBE	SCREW	TE 10 x 20 UNI 5739		
22	62010200	4	DADO	ECROU	MUTTER	NUT	M 8 x 1,25 AUTOBLOCC.		
23	60020400	4	VITE	VIS	SCHRAUBE	SCREW	TE 12 x 25 UNI 5739		
24	62010600	4	DADO	ECROU	MUTTER	NUT	M 12 x 1,75 AUTOBLOCC.		
25	41130400	1	TELAIO	CHASSIS	RAHMEN	FRAME	105		
25	41130500	1	TELAIO	CHASSIS	RAHMEN	FRAME	130		
25	41130600	1	TELAIO	CHASSIS	RAHMEN	FRAME	155		
25	41131200	1	TELAIO	CHASSIS	RAHMEN	FRAME	180		
26	60044400	5	VITE	VIS	SCHRAUBE	SCREW	TE 12 x 20 UNI 5739		
27	62010600	5	DADO	ECROU	MUTTER	NUT	M 12 x 1,75 AUTOBLOCC.		
28	39325800	1	PROTEZIONE	PROTECTION	SCHUTZ	GUARD	105		
28	39325900	1	PROTEZIONE	PROTECTION	SCHUTZ	GUARD	130		
28	39326000	1	PROTEZIONE	PROTECTION	SCHUTZ	GUARD	155		
28	39335200	1	PROTEZIONE	PROTECTION	SCHUTZ	GUARD	180		
29	39357900	1	BANDELLA	BANDE	BAND	STRAP			
30	60021300	4	VITE	VIS	SCHRAUBE	SCREW	TE 10 x 30 UNI 5739		
31	61003500	2	RONDELLA	RONDELLE	SCHEIBE	WASHER	PIANA Øi 11 Øe 30		
32	31079300	4	BOCCOLA	DOUILLE	BUECHSE	BUSHING			
33	62010400	4	DADO	ECROU	MUTTER	NUT	M 10 x 1,5 AUTOBLOCC.		
34	60047600	2	VITE	VIS	SCHRAUBE	SCREW	TE 22 x 40 ZNT	131676	

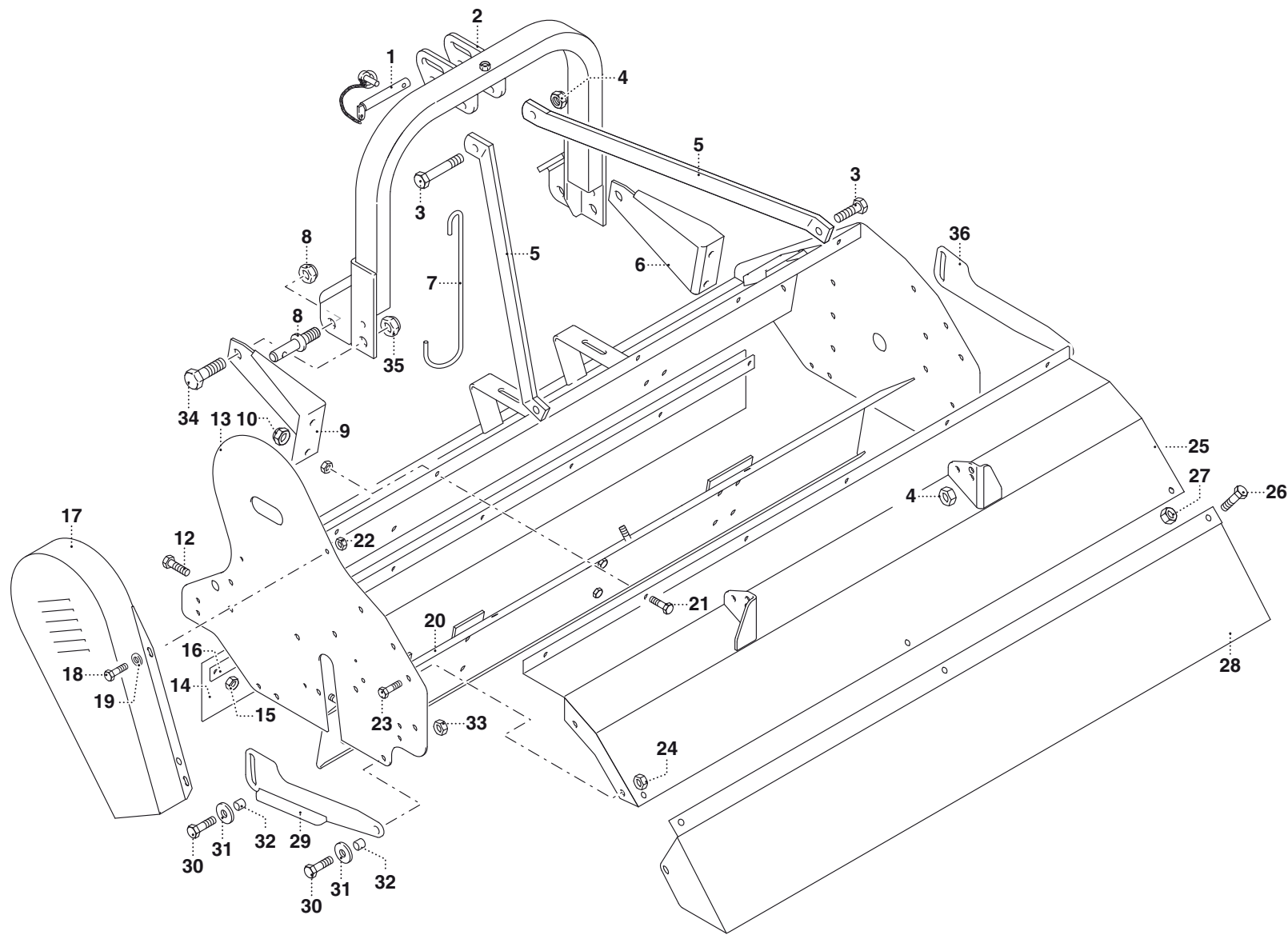





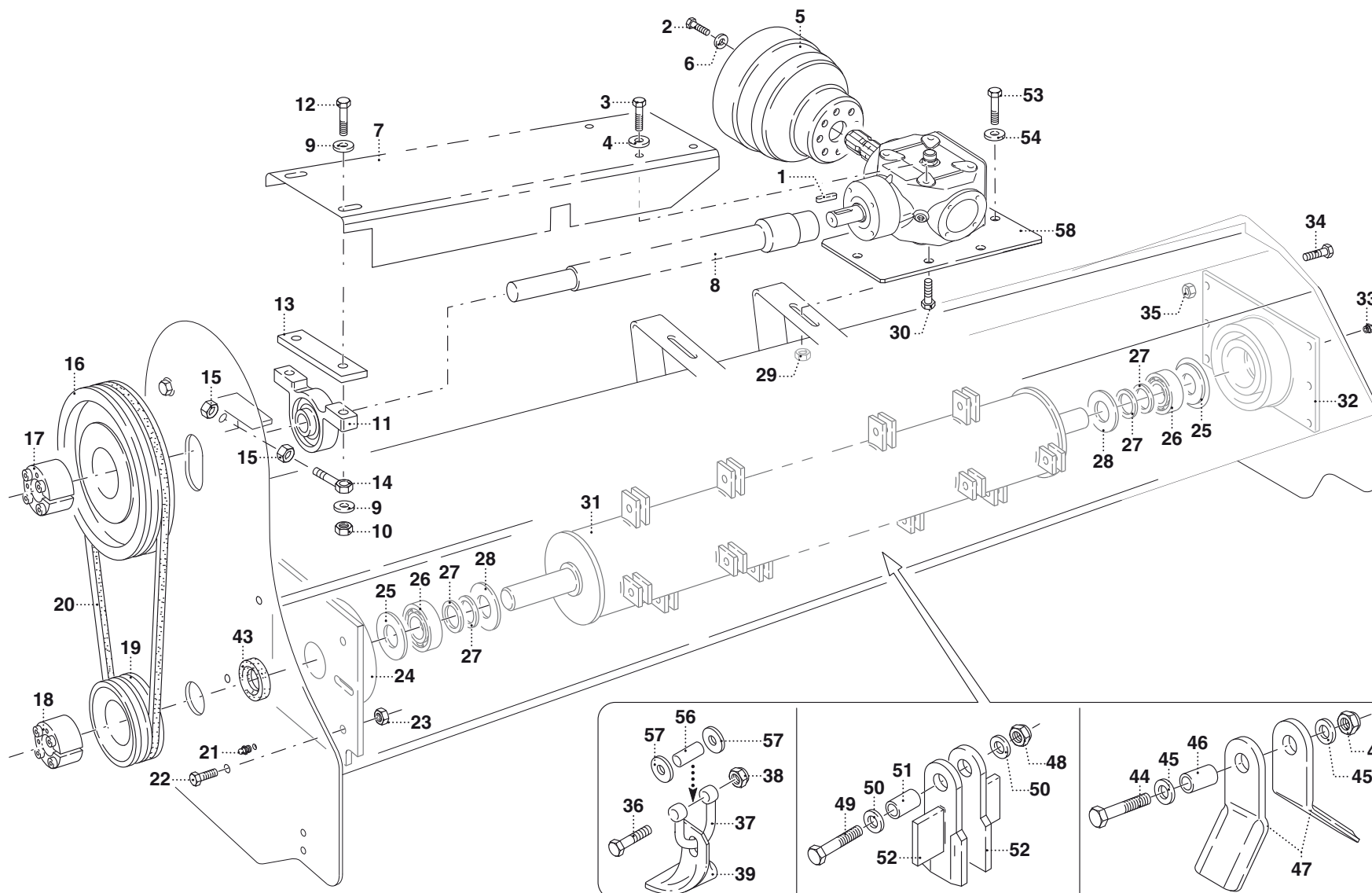

# MURATORI MT 30

# TAV. 2.0

POS.	N°	CODICE Q.	DESCRIZIONE	DESIGNATION	BENENNUNG	DESCRIPTION	DESIGNAZIONE	Da matr.	Fino matr.
								De nr. serie Vom Seriennr. From serial nr.	Jusqu'au nr. serie Bis Seriennr. Up to serial nr.
1	65001100	1	LINGUETTA	CLAVETTE	FEDER	KEY	8 x 7 x 30 UNI 6604		
2	60015100	2	VITE	VIS	SCHRAUBE	SCREW	TE 8 x 16 UNI 5739		
3	60021600	2	VITE	VIS	SCHRAUBE	SCREW	TE 10 x 130 UNI 5737		
4	61004900	2	RONDELLA	RONDELLE	SCHEIBE	WASHER	PIANA Ø 10 UNI 6592		
5	68074300	1	PROTEZIONE	PROTECTION	SCHUTZ	GUARD			
6	61004700	2	RONDELLA	RONDELLE	SCHEIBE	WASHER	PIANA Ø 8 UNI 6592		
7	40265801	1	PROTEZIONE	PROTECTION	SCHUTZ	GUARD	105		
7	40265901	1	PROTEZIONE	PROTECTION	SCHUTZ	GUARD	130		
7	40266001	1	PROTEZIONE	PROTECTION	SCHUTZ	GUARD	155		
7	40288100	1	PROTEZIONE	PROTECTION	SCHUTZ	GUARD	180		
8	40228501	1	PROLUNGA	RALLONGE	VERLÄNGERUNGSROHR	EXTENSION	105		
8	40228601	1	PROLUNGA	RALLONGE	VERLÄNGERUNGSROHR	EXTENSION	130		
8	40228701	1	PROLUNGA	RALLONGE	VERLÄNGERUNGSROHR	EXTENSION	155		
8	40228701	1	PROLUNGA	RALLONGE	VERLÄNGERUNGSROHR	EXTENSION	180		
9	61005000	3	RONDELLA	RONDELLE	SCHEIBE	WASHER	PIANA Ø 12 UNI 6592		
10	62010600	2	DADO	ECROU	MUTTER	NUT	M 12 x 1,75 AUTOBLOCC.		
11	67012600	1	SUPPORTO	SUPPORT	TRAEGER	SUPPORT	UCP 205		
12	60010100	2	VITE	VIS	SCHRAUBE	SCREW	TE 12 x 65 UNI 5737		
13	30212500	1	SPESSORE	EPAISSEUR	DISTANZRING	SPACER			
14	40161400	1	TIRANTE	TIRANT	STANGE	TIEROD			
15	62007000	2	DADO	ECROU	MUTTER	NUT	M 10 x 1,5 UNI 5588		
16	68121200	1	PULEGGIA	POULIE	RIEMENSCHIEBE	PULLEY	Ø 170 3 SPA		
17	68058900	1	CALETTATORE	DISPOSITIF D'ASSEMBLAGE	SPANNSATZ	LOCKING DEVICE	Øi 25 Øe 55		
18	68059000	1	CALETTATORE	DISPOSITIF D'ASSEMBLAGE	SPANNSATZ	LOCKING DEVICE	Øi 35 Øe 55		
19	68059200	1	PULEGGIA	POULIE	RIEMENSCHIEBE	PULLEY	Ø 100 3 SPA		
20	68121300	3	CINGHIA	COURROIE	KEILRIEMEN	BELT	A 41		

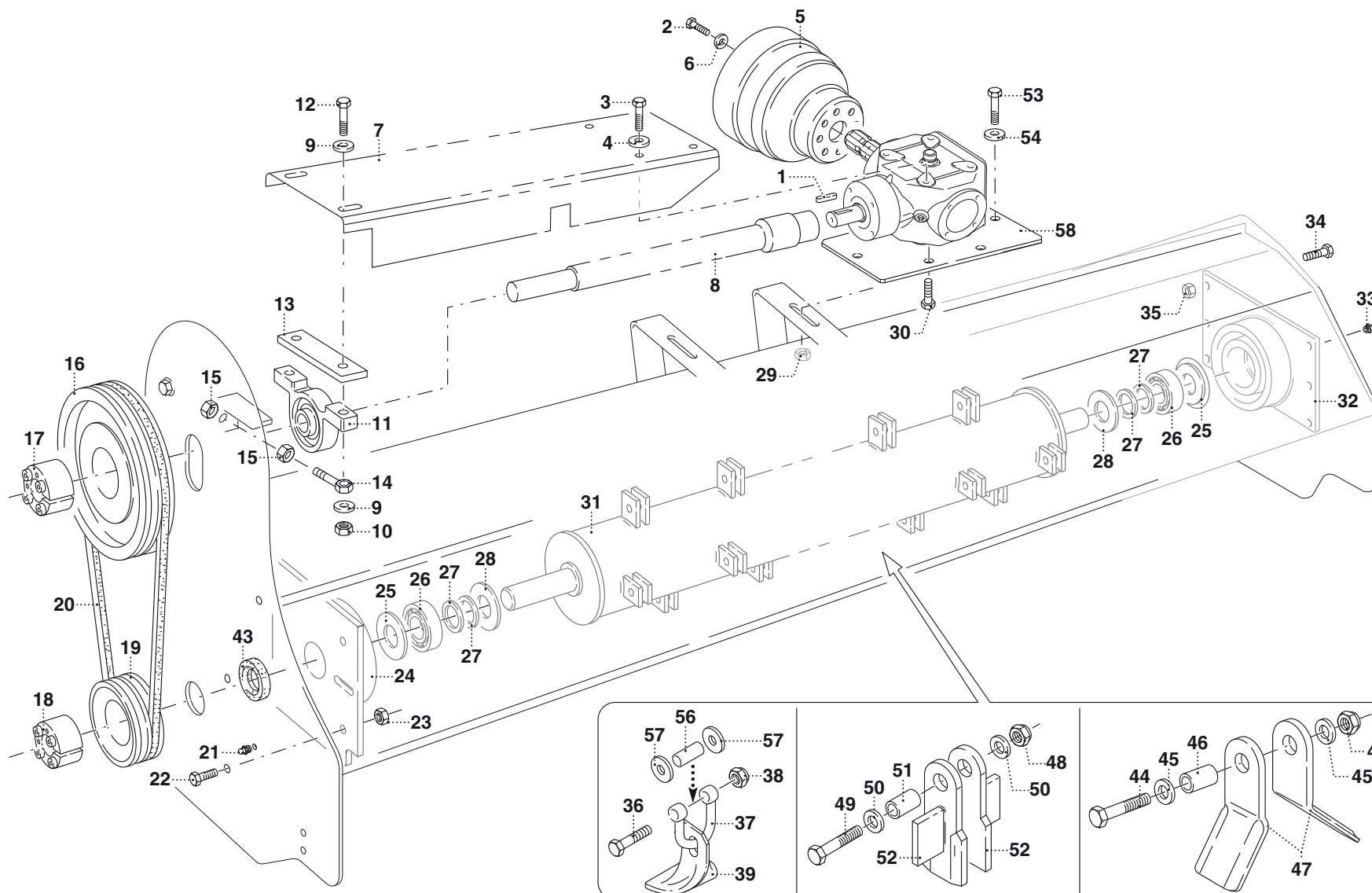

## MURATORI MT 30

## TAV. 2.0

POS.	N°	CODICE Q.	DESCRIZIONE	DESIGNATION	BENENNUNG	DESCRIPTION	DESIGNAZIONE	Da matr. De nr. serie Vom Seriennr. From serial nr.	Fino matr. Jusqu'au nr. serie Bis Seriennr. Up to serial nr.
21	64000200	1	INGRASSATORE	GRAISSEUR	SCHMIERNIPPEL	GREASE FITTING	M 6 x 1		
22	60020400	4	VITE	VIS	SCHRAUBE	SCREW	TE 12 x 25 UNI 5735		
23	62010600	4	DADO	ECROU	MUTTER	NUT	M 12 x 1,75 AUTOBLOCC.		
24	40228000	1	SUPPORTO SX	SUPPORT (G)	TRÄGER (LINKS)	SUPPORT (LH)			
25	32068000	2	SPESSORE	EPAISSEUR	DICKE	THICKNESS			
26	67012900	2	CUSCINETTO	ROULEMENT	LAGER	BEARING	1306		
27	68068800		SPESSORE	EPAISSEUR	DISTANZRING	SPACER	42 x 30 x 1		
28	39091100	2	DISCO	DISQUE	SCHEIBE	DISC	Øe 70 Øi 30 sp. 1,5		
29	62010600	2	DADO	ECROU	MUTTER	NUT	M 12 x 1,75 AUTOBLOCC.		
30	60021600	4	VITE	VIS	SCHRAUBE	SCREW	TE 10 x 20 UNI 5739		
31	42045400	1	ROTORE	ROTOR	ROTOR	ROTOR	105		
31	42045500	1	ROTORE	ROTOR	ROTOR	ROTOR	130		
31	42045600	1	ROTORE	ROTOR	ROTOR	ROTOR	155		
31	42077800	1	ROTORE	ROTOR	ROTOR	ROTOR	180		
32	40084600	1	SUPPORTO DX	SUPPORT (D)	TRÄGER (RECHTS)	SUPPORT (RH)			
33	64001800	1	INGRASSATORE	GRAISSEUR	SCHMIERNIPPEL	GREASE FITTING	M 10 x 1 DIRITTO		
34	60020400	6	VITE	VIS	SCHRAUBE	SCREW	TE 12 x 25 UNI 5739		
35	62010600	6	DADO	ECROU	MUTTER	NUT	M 12 x 1,75 AUTOBLOCC.		
36	60007700		VITE	VIS	SCHRAUBE	SCREW	TE 14 x 70 UNI 5737		
36	60023300	2	VITE	VIS	SCHRAUBE	SCREW	TE 14 x 60 UNI 5737		136326
36	60030200		VITE	VIS	SCHRAUBE	SCREW	TE 10 x 80 UNI 5739 8.8 ZNT	136327	
37	68074000		CAVALLOTTO	ARRETOIR	KLEMMSTÜCK	UBOLT			136326
37	68129200		CAVALLOTTO	ARRETOIR	KLEMMSTÜCK	UBOLT		136327	
38	62010800		DADO	ECROU	MUTTER	NUT	M 14 x 2 AUTOBLOCC.		136326
38	62010400		DADO	ECROU	MUTTER	NUT	M 10 x 1,5 AUTOBLOCC.	136327	
39	12015100		COLTELLO A SPATOLE	COUTEAU	MESSER	KNIFE			

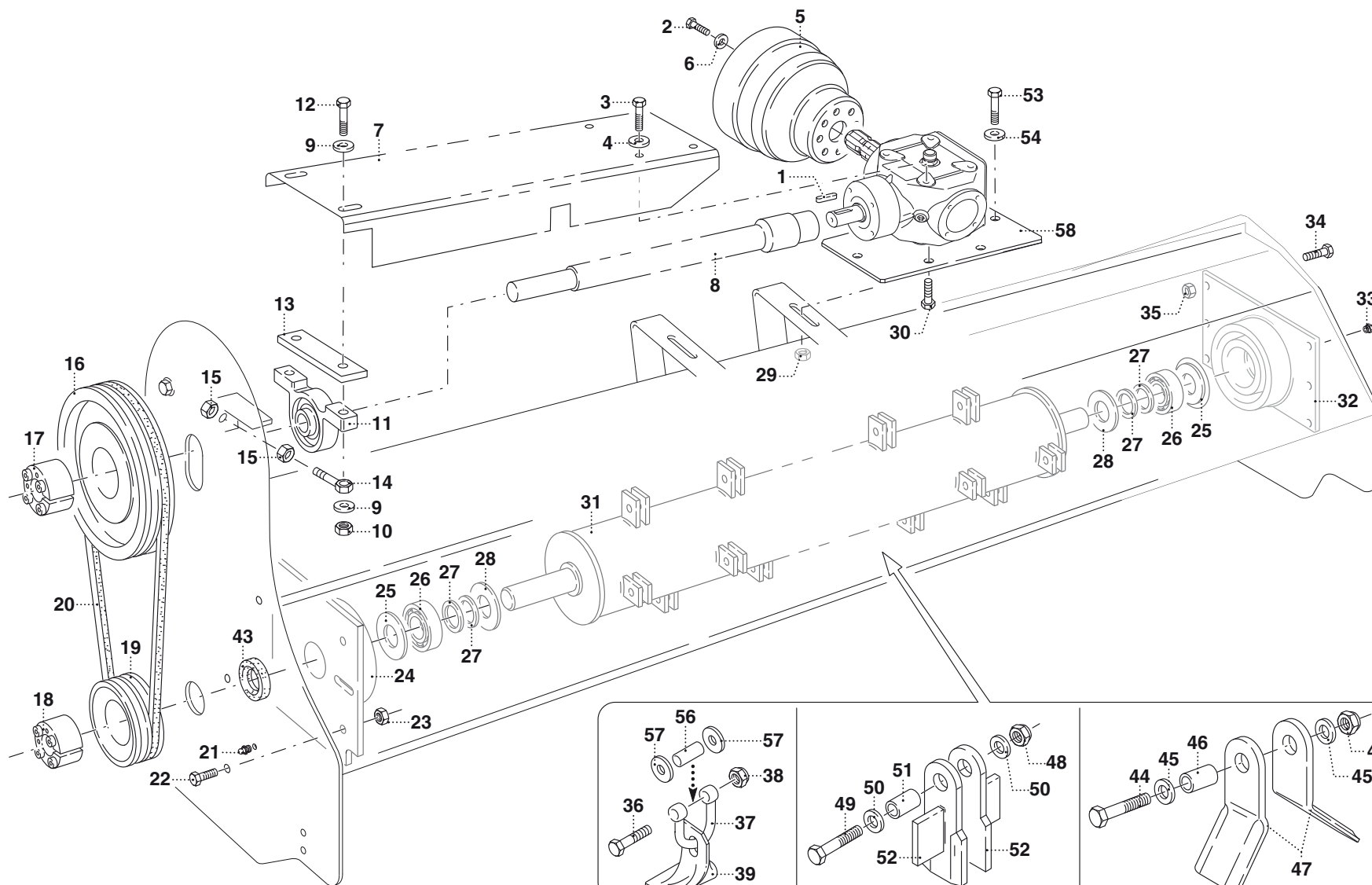



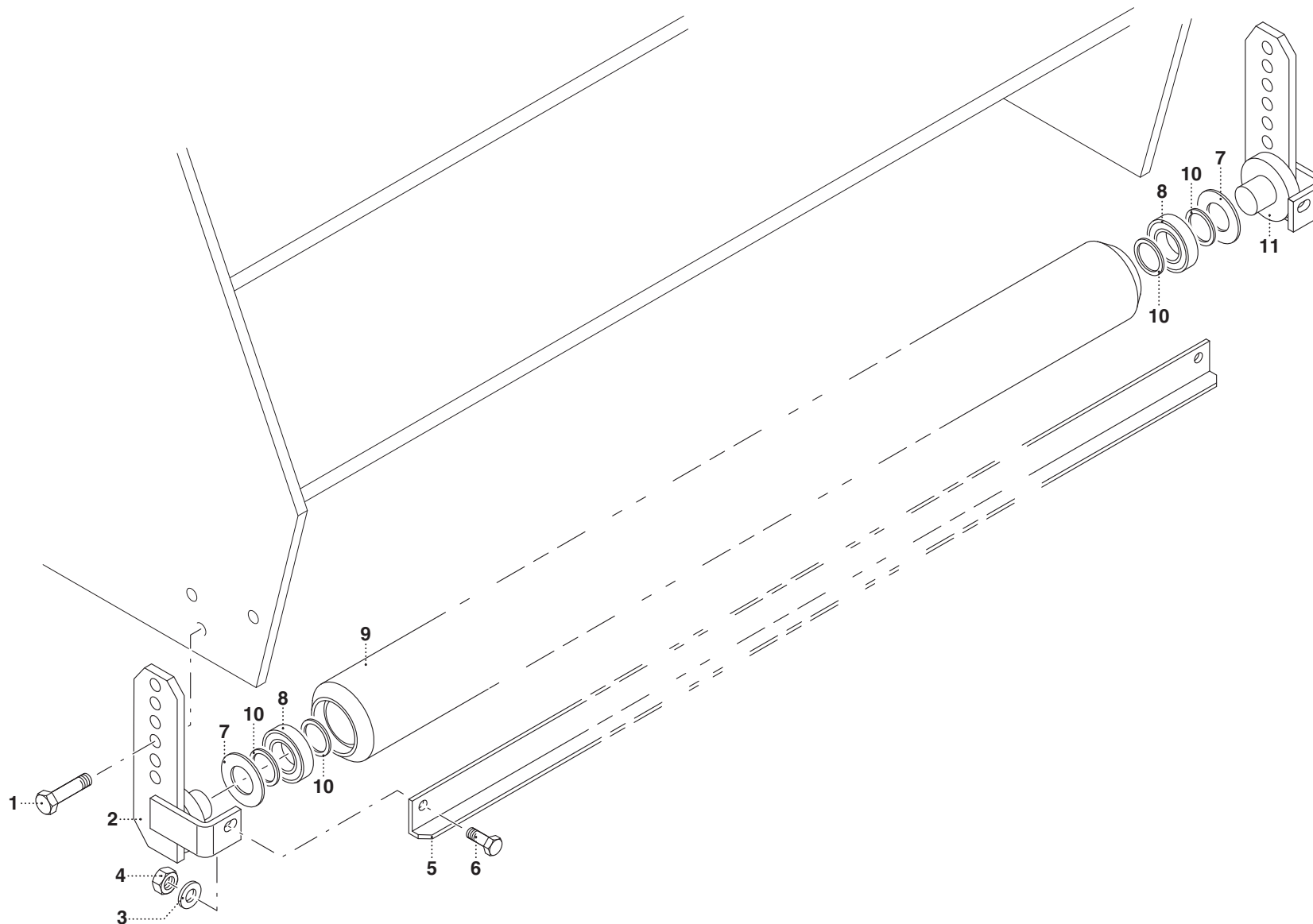



## MURATORI MT 30

TAV. 3.0

POS.	N°	CODICE Q.	DESCRIZIONE	DESIGNATION	BENENNUNG	DESCRIPTION	DESIGNAZIONE	Da matr.	Fino matr.
								De nr. serie Vom Seriennr. From serial nr.	Jusqu'au nr. serie Bis Seriennr. Up to serial nr.
1	60017900	4	VITE	VIS	SCHRAUBE	SCREW	TE 10 x 25 UNI 5739		
2	40234700	1	SUPPORTO SX	SUPPORT (G)	TRÄGER (LINKS)	SUPPORT (LH)			
3	61004700	2	RONDELLA	RONDELLE	SCHEIBE	WASHER	PIANA Ø 8 UNI 6592		
4	62010200	2	DADO	ECROU	MUTTER	NUT	M 8 x 1,25 AUTOBLOCC.		
5	34012300	1	RASCHIARULLO	GRATTOIR	SCHABEISEN	SCRAPER	105		
5	34011000	1	RASCHIARULLO	GRATTOIR	SCHABEISEN	SCRAPER	130		
5	34012400	1	RASCHIARULLO	GRATTOIR	SCHABEISEN	SCRAPER	155		
5	34032000	1	RASCHIARULLO	GRATTOIR	SCHABEISEN	SCRAPER	180		
6	60022800	2	VITE	VIS	SCHRAUBE	SCREW	TE 8 x 20 UNI 5739		
7	39200500	2	DISCO	DISQUE	SCHEIBE	DISC			
8	67017500	2	CUSCINETTO	ROULEMENT	LAGER	BEARING	6305 2RS		
9	42.0710.00	1	RULLO LIVELLATORE	ROULEAU ARRIERE	HINTERERSTÜTZWALZE	REAR ROLLER	105		
9	42.0711.00	1	RULLO LIVELLATORE	ROULEAU ARRIERE	HINTERERSTÜTZWALZE	REAR ROLLER	130		
9	42.0712.00	1	RULLO LIVELLATORE	ROULEAU ARRIERE	HINTERERSTÜTZWALZE	REAR ROLLER	155		
9	42.0779.00	1	RULLO LIVELLATORE	ROULEAU ARRIERE	HINTERERSTÜTZWALZE	REAR ROLLER	180		
10	68028400	2	SPESSORE	EPAISSEUR	DISTANZRING	SPACER	35 x 25 x 1		
11	40234800	1	SUPPORTO DX	SUPPORT (D)	TRÄGER (RECHTS)	SUPPORT (RH)			

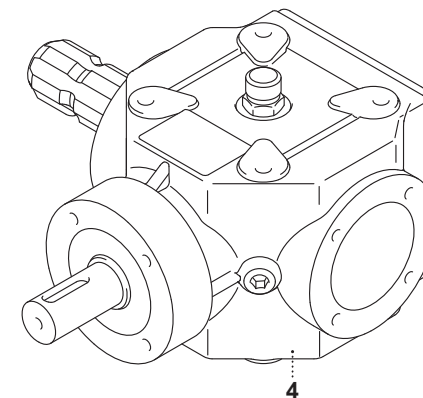
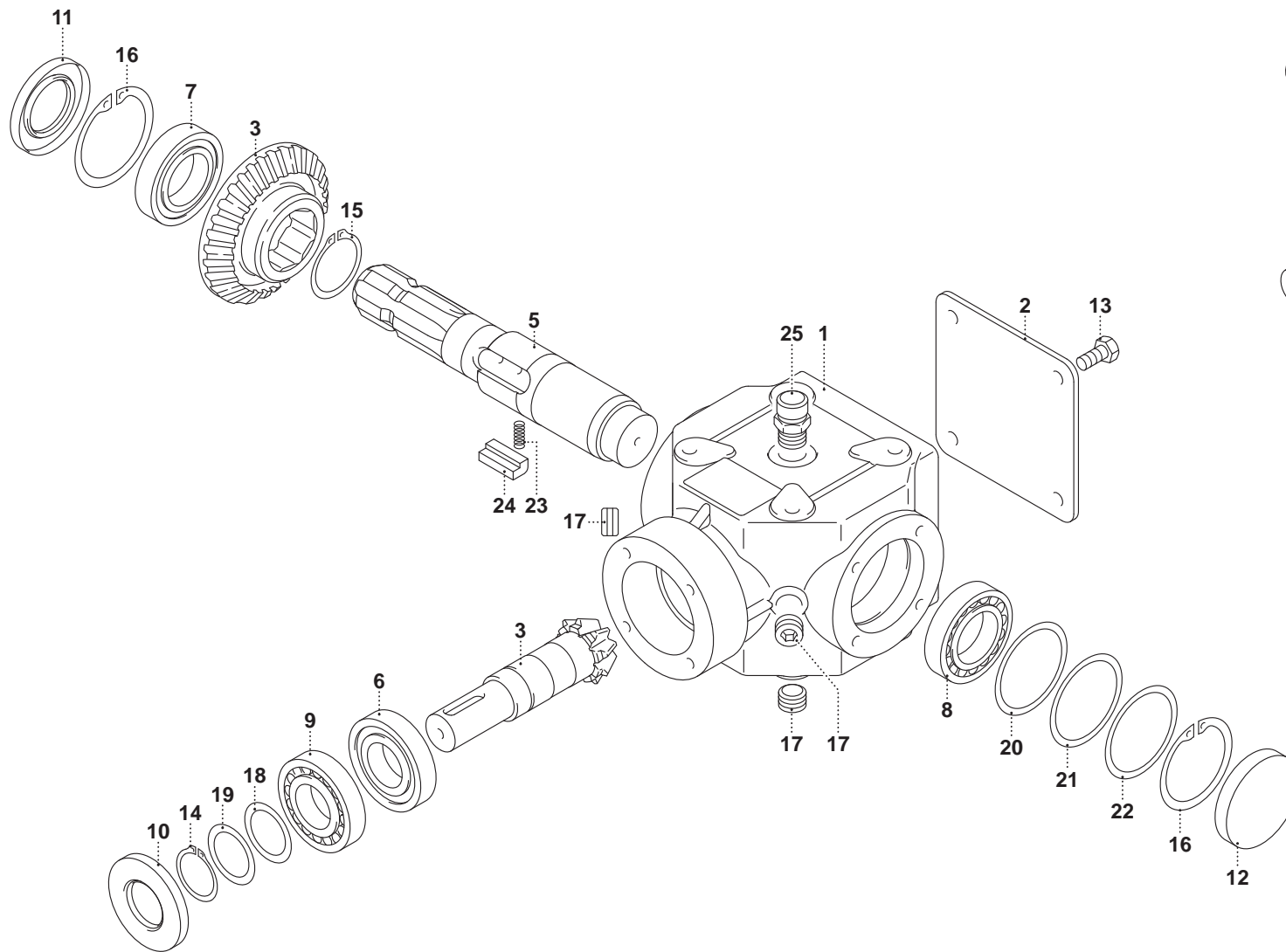

# MURATORI MT 30

# TAV. 4.0

POS.	N°	CODICE Q.	DESCRIZIONE	DESIGNATION	BENENNUNG	DESCRIPTION	DESIGNAZIONE	Da matr.	Fino matr.
								De nr. serie Vom Seriennr. From serial nr.	Jusqu'au nr. serie Bis Seriennr. Up to serial nr.
1		01020400 1	SCATOLA	CARTER	GEHAEUSE	GEARBOX			
2		39340600 1	COPERCHIO	COUVERCLE	DECKEL	COVER			
3		10050900 1	COPPIA CONICA	COUPLE CONIQUE	KEGELRADTRIEB.	BEVEL GEAR PAIR			
4		46042000 1	MOLTIPLICATORE ORARIO BOITIER (ROT. STANDARD)	RECHTSDR. GETRIEBE	CLOCKWISE GEAR BOX				
4		46042200 1	MOLTIPLIC. ANTIORARIO BOITIER (ROT. INVERSE)	LINKSDR. GETRIEBE	COUNTERCL. GEAR BOX				
5		31099200 1	ALBERO	ARBRE	WELLE	SHAFT			
6		67015700 1	CUSCINETTO	ROULEMENT	LAGER	BEARING	30206		
7		67017200 1	CUSCINETTO	ROULEMENT	LAGER	BEARING	30207		
8		67018500 1	CUSCINETTO	ROULEMENT	LAGER	BEARING	6007		
9		67018600 1	CUSCINETTO	ROULEMENT	LAGER	BEARING	6206		
10		66019700 1	ANELLO TENUTA	JOINT D'ETANCHEITE	DICHTUNGSRING	JUNT RING	30 x 62 x 8		
11		66011600 1	ANELLO TENUTA	JOINT D'ETANCHEITE	DICHTUNGSRING	JUNT RING	35 x 62 x 7		
12		68123900 1	CAPPELOTTO	BOUCHON	ABSCHLUSSKAPPE	CAP NUT	62 x 9,5		
13		60015100 4	VITE	VIS	SCHRAUBE	SCREW	TE 8 x 16 UNI 5739		
14		63005700 1	ANELLO ELASTICO	ARRETOIR	SPANNRING	SNAP-RING	Ø30 E UNI 7436		
15		63005000 1	ANELLO ELASTICO	ARRETOIR	SPANNRING	SNAP-RING	Ø42 E UNI 7435		
16		63005200 1	ANELLO ELASTICO	ARRETOIR	SPANNRING	SNAP-RING	Ø62 I UNI 7437		
17		68124500 3	TAPPO	BOUCHON	STOPFEN	PLUG			
18		68124100 1	SPESSORE	EPAISSEUR	DISTANZRING	SPACER	30 x 40 x 0,5		
19		68124200 1	SPESSORE	EPAISSEUR	DISTANZRING	SPACER	30 x 40 x 1		
20		68039000 1	SPESSORE	EPAISSEUR	DISTANZRING	SPACER	62 x 50 x 0,3		
21		68124300 1	SPESSORE	EPAISSEUR	DISTANZRING	SPACER	62 x 50 x 0,5		
22		68011500 2	SPESSORE	EPAISSEUR	DISTANZRING	SPACER	62 x 50 x 1		
23		68124400 4	MOLLA	RESSORT	FEDER	SPRING			
24		65003500 2	CHIAVETTA	CLAVETTE	KEIL	SPLINE			
25		68085600 1	TAPPO	BOUCHON	STOPFEN	PLUG			

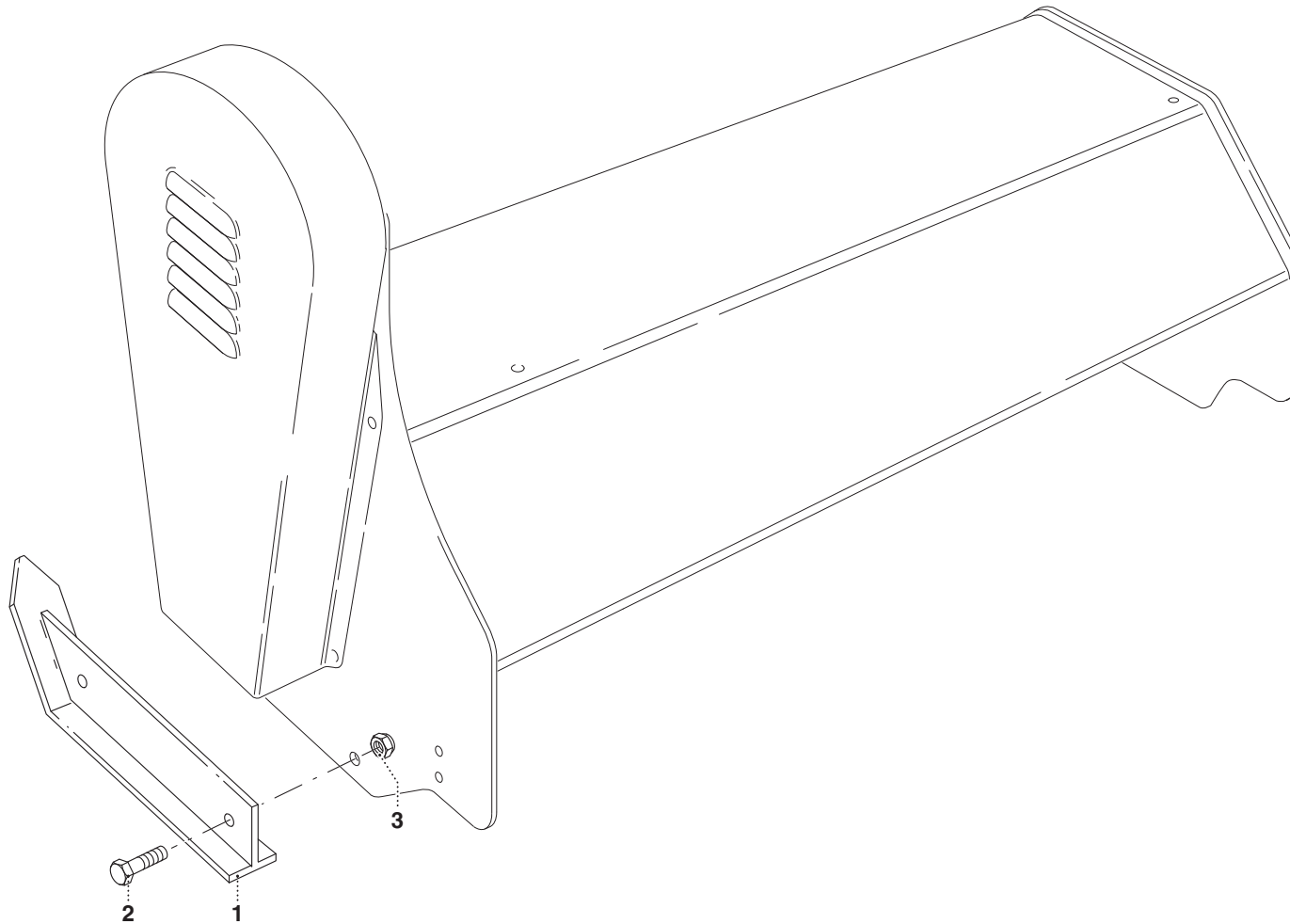

POS.	N° CODICE Q.	DESCRIZIONE	DESIGNATION	BENENNUNG	DESCRIPTION	DESIGNAZIONE	Da matr.	Fino matr.
							De nr. serie Vom Seriennr. From serial nr.	Jusqu'au nr. serie Bis Seriennr. Up to serial nr.
1	40228200 2	SLITTA	PATIN	STUTZKUFEN	SKID			
2	60020400 4	VITE	VIS	SCHRAUBE	SCREW	TE 12 x 25 UNI 5739		
3	62010600 4	DADO	ECROU	MUTTER	NUT	M 12 x 1,75 AUTOBLOCC.		

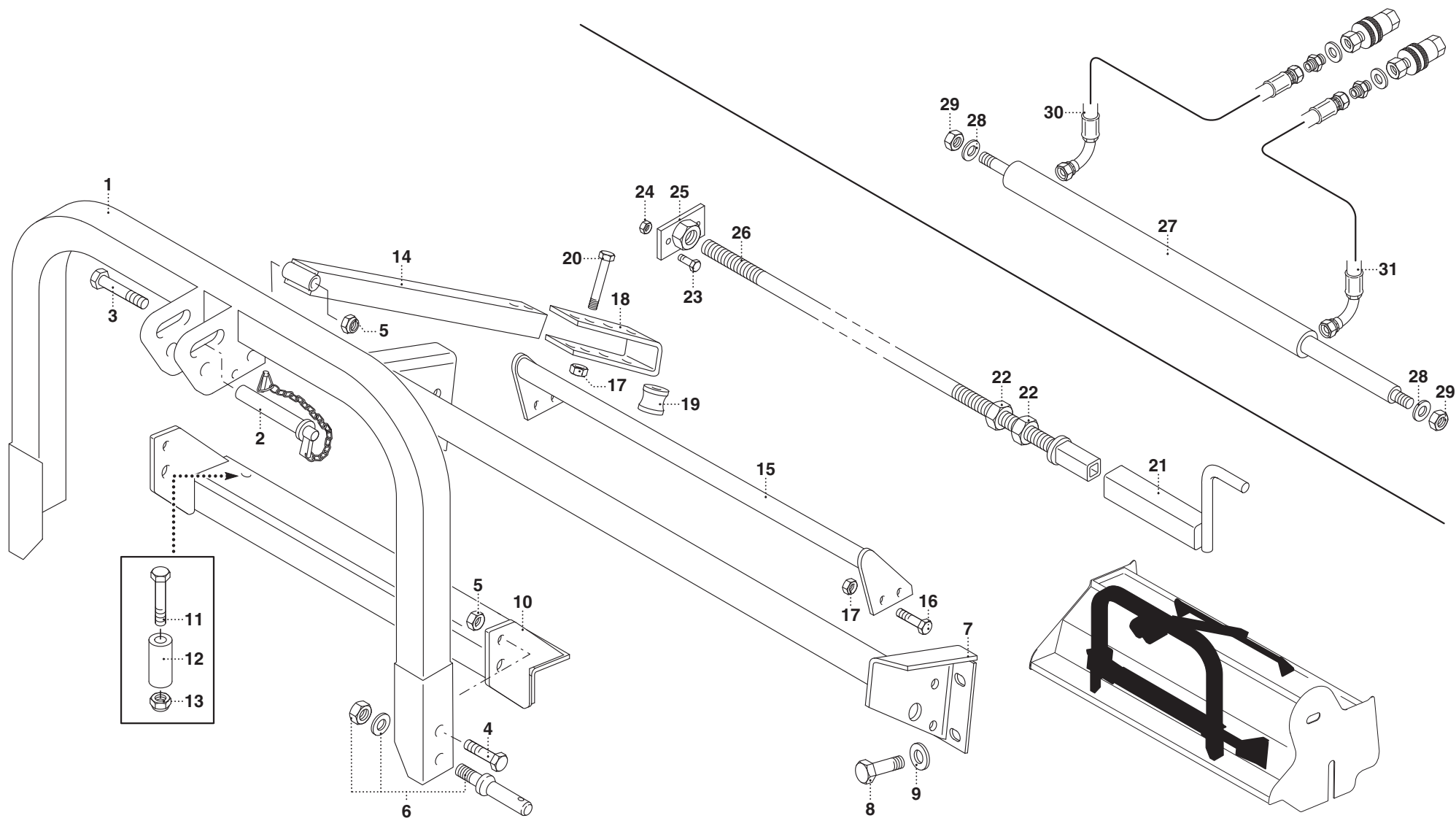

# MURATORI MT 30

# TAV. 6.0

POS.	N°	CODICE Q.	DESCRIZIONE	DESIGNATION	BENENNUNG	DESCRIPTION	DESIGNAZIONE	Da matr.	Fino matr.
								De nr. serie Vom Seriennr. From serial nr.	Jusqu'au nr. serie Bis Seriennr. Up to serial nr.
1	40315700	1	ATTACCO	ATTACHE	ANSCHLUSS	ATTACHMENT			
2	68062000	2	PERNO	PIVOT	BOLZEN	PIN			
3	60030500	1	VITE	VIS	SCHRAUBE	SCREW	TE 12 x 100 UNI 5737		
4	60021200	2	VITE	VIS	SCHRAUBE	SCREW	TE 12 x 35 UNI 5739		
5	62010600	3	DADO	ECROU	MUTTER	NUT	M 12 x 1,75 AUTOBLOCC.		
6	68062500	2	PERNO	PIVOT	BOLZEN	PIN			
7	40267800	1	TELAIO	CHASSIS	RAHMEN	FRAME			
8	60023000	4	VITE	VIS	SCHRAUBE	SCREW	TE 12 x 30 UNI 5739		
9	61005000	4	RONDELLA	RONDELLE	SCHEIBE	WASHER	PIANA Ø 12 UNI 6592		
10	40267900	1	CARRELLO	CHARIOT	WAGEN	CAR			
11	60021500	2	VITE	VIS	SCHRAUBE	SCREW	TE 12 x 80 UNI 5737		
12	32183700	2	DISTANZIALE	ENTRETOISE	DISTANZSTÜCK	SPACER			
13	62010600	2	DADO	ECROU	MUTTER	NUT	M 12 x 1,75 AUTOBLOCC.		
14	40268100	1	TIRANTE	TIRANT	STANGE	TIEROD			
15	40268000	1	SOSTEGNO	SUPPORT	TRAEGER	SUPPORT			
16	60023000	4	VITE	VIS	SCHRAUBE	SCREW	TE 12 x 30 UNI 5739		
17	62010600	8	DADO	ECROU	MUTTER	NUT	M 12 x 1,75 AUTOBLOCC.		
18	30113600	1	STAFFA	BRIDE	BUEGEL	BRACKET			
19	38018500	2	RULLINO	GALET	ROLLE	NEEDLE PIN			
20	60024400	4	VITE	VIS	SCHRAUBE	SCREW	TE 12 x 70 UNI 5737		
21	40121700	1	MANOVELLA	MANIVELLE	KURBEL	CRANK			
22	62014700	2	CHIOCCIOLA	ECROU EN CARACOLE	MUTTERSCHLOSS	LEAD NUT			
23	60036200	2	VITE	VIS	SCHRAUBE	SCREW	TE 8 x 35 UNI 5739		
24	62010200	2	DADO	ECROU	MUTTER	NUT	M 8 x 1,25 AUTOBLOCC.		
25	40246800	1	CHIOCCIOLA	ECROU EN CARACOLE	MUTTERSCHLOSS	LEAD NUT			
26	40247000	1	VITE	VIS	SCHRAUBE	SCREW			

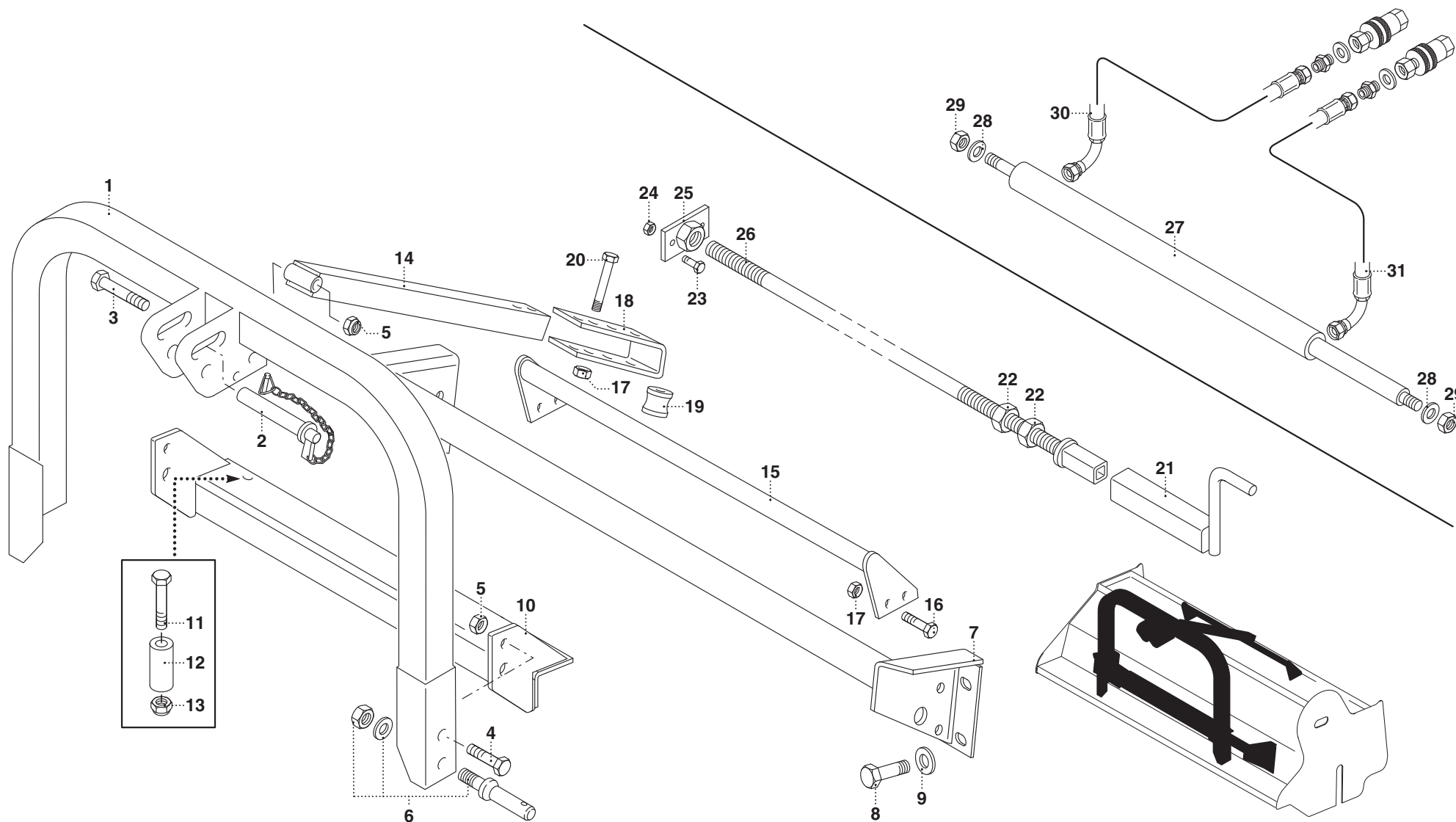





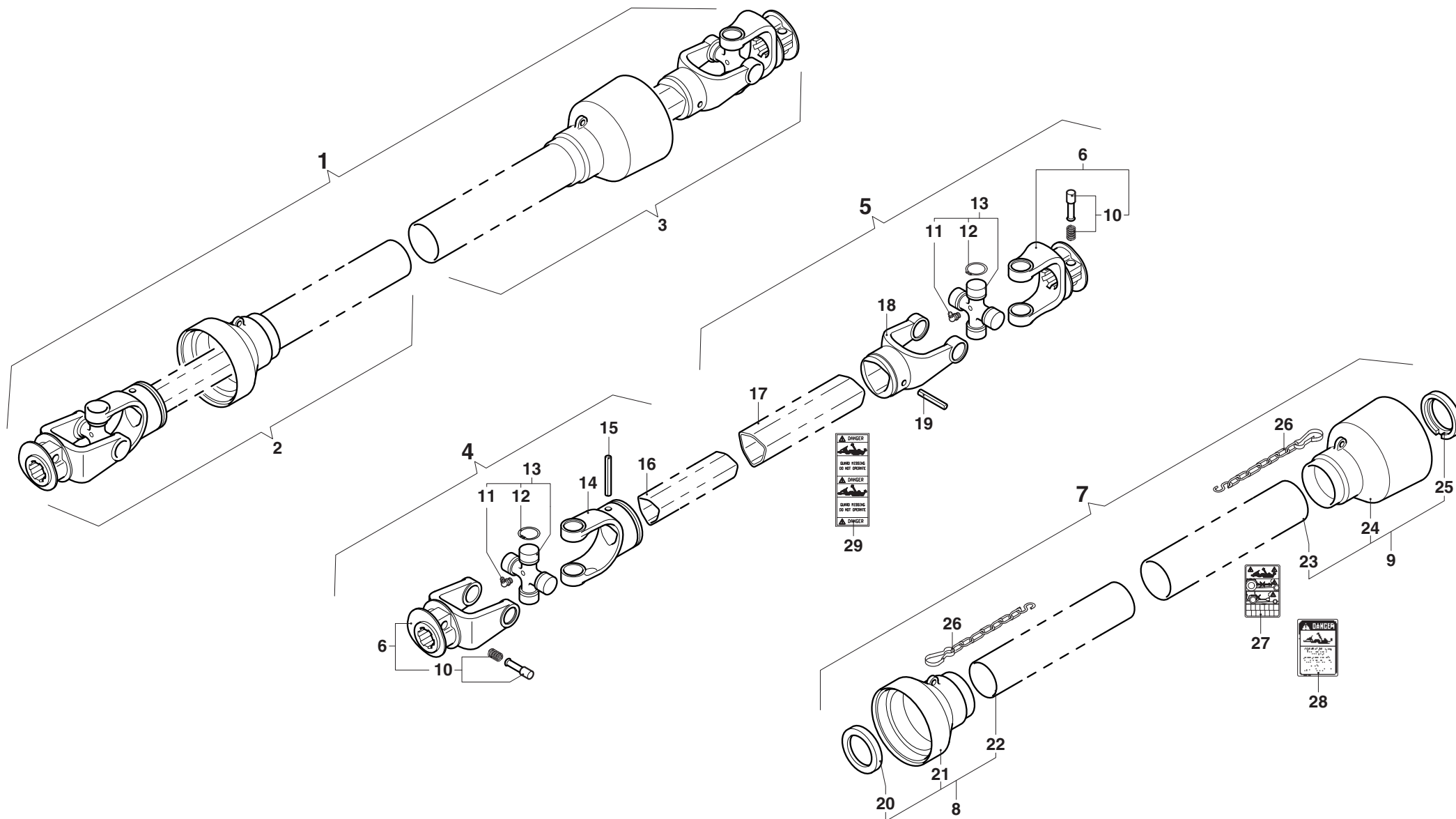

# MURATORI MT 30

# TAV. 7.0

POS.	N° CODICE Q.	DESCRIZIONE	DESIGNATION	BENENNUNG	DESCRIPTION	DESIGNAZIONE	Da matr.	Fino matr.
							De nr. serie Vom Seriennr. From serial nr.	Jusqu'au nr. serie Bis Seriennr. Up to serial nr.
1	AB207SF 1	ALBERO CARDANICO COMPLETO	ARBRE A JOINTS DE CARDAN	KARDANWELLE	PTO SHAFT			
2	B2070B1 1	SEMIALBERO INTERNO	DEMI-ARBRE INTERIEUR	INNENHALBWELLE	INTERNAL HALF SHAFT			
3	B2070B2 1	SEMIALBERO ESTERNO	DEMI-ARBRE EXTERIEUR	AUSSENHALBWELLE	EXTERNAL HALF SHAFT			
4	B207001 1	SEMIALBERO INTERNO	DEMI-ARBRE INTERIEUR	INNENHALBWELLE	INTERNAL HALF SHAFT			
5	B2070002 1	SEMIALBERO ESTERNO	DEMI-ARBRE EXTERIEUR	AUSSENHALBWELLE	EXTERNAL HALF SHAFT			
6	0800203 2	FORCELLA	FOURCHE	GABEL	YOKE			
7	083B02070 1	PROTEZIONE	PROTECTION	SCHUTZ	GUARD			
8	083B020701 1	PROTEZIONE INTERNA	PROTECTION INTERIEURE	INNENSCHUTZ	INTERNAL GUARD			
9	083B020702 1	PROTEZIONE ESTERNA	PROTECTION EXTERIEURE	AUSSENSCHUTZ	EXTERNAL GUARD			
10	0986014047 2	PULSANTE	BOUTON	DRUCKKNOPF	PUSH BOTTON			
11	09840081002 2	INGRASSATORE	GRAISSEUR	SCHMIERNIPPEL	GREASE FITTING			
12	098020224 8	ANELLO ELASTICO	ARRETOIR	SPANNRING	SNAP-RING			
13	08202 2	CROCIERA	CROISILLON	KREUZSTÜCK	SPIDER			
14	08002011 1	FORCELLA	FOURCHE	GABEL	YOKE			
15	098700850 1	SPINA ELASTICA	GOUPILLE ELASTIQUE	SPANNSTIFT	ELASTIC PIN			
16	09881294100 1	TUBO INTERNO	TUBE INTERIEUR	INNENROHR	INTERNAL TUBE			
17	09881363100 1	TUBO ESTERNO	TUBE EXTERIEUR	AUSSENROHR	EXTERNAL TUBE			
18	08002021 1	FORCELLA	FOURCHE	GABEL	YOKE			
19	098700855 1	SPINA ELASTICA	GOUPILLE ELASTIQUE	SPANNSTIFT	ELASTIC PIN			
20	0265220008 1	GHIERA	FRETTE	NUTMUTTER	RING NUT			
21	0256010425 1	CUFFIA	CAPOUCHON	HAUBE	GUARD			
22	0988955B2070 1	TUBO INTERNO	TUBE INTERIEUR	INNENROHR	INTERNAL TUBE			
23	0988961B2070 1	TUBO ESTERNO	TUBE EXTERIEUR	AUSSENROHR	EXTERNAL TUBE			
24	0256010424 1	CUFFIA	CAPOUCHON	HAUBE	GUARD			
25	0265220007 1	GHIERA	FRETTE	NUTMUTTER	RING NUT			

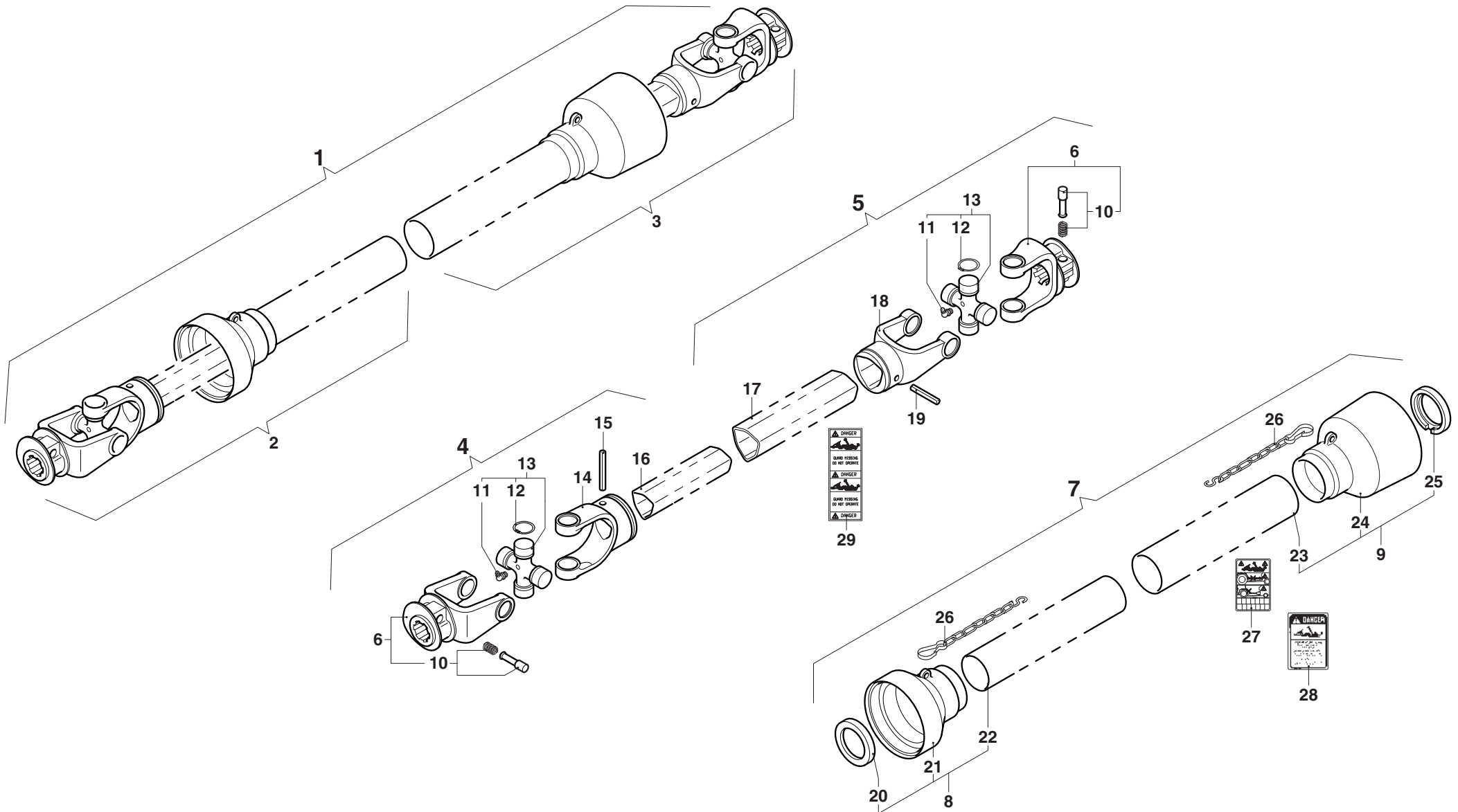









**MURATORI S.p.A.**

Via Pavarello, 21 - 41051 Castelnuovo Rangone (MO) Italy - Tel. 059.5330611 Fax 059.537259

[www.muratoriequip.it](http://www.muratoriequip.it) [info@muratoriequip.it](mailto:info@muratoriequip.it)

Capitale sociale Euro 480.000 interamente versato

Registro Imprese di Modena

Codice fiscale e numero d'iscrizione: 00708860366

 **Miniwerk**tuigenshop